

# 超小型衛星VERTECSに搭載する 可視光検出器の性能評価

廣瀬優樹, 松浦周二, 橋本遼, 小鹿哲雅, 津本明音, 大原有稀, 夷子真生,  
大藤勇亮, 廣瀬理紗 (関西学院大), 當銘優斗, 佐野圭, 中川俊輔 (九州工業大),  
津村耕司 (東京都市大), 中川貴雄 (東京都市大, ISAS/JAXA),  
瀧本幸司, 高橋葵, 田中颯 (ISAS/JAXA), VERTECS collaboration

# 1. Overview of the detector for VERTECS



## Observation instrument

VERTECS  
6U size

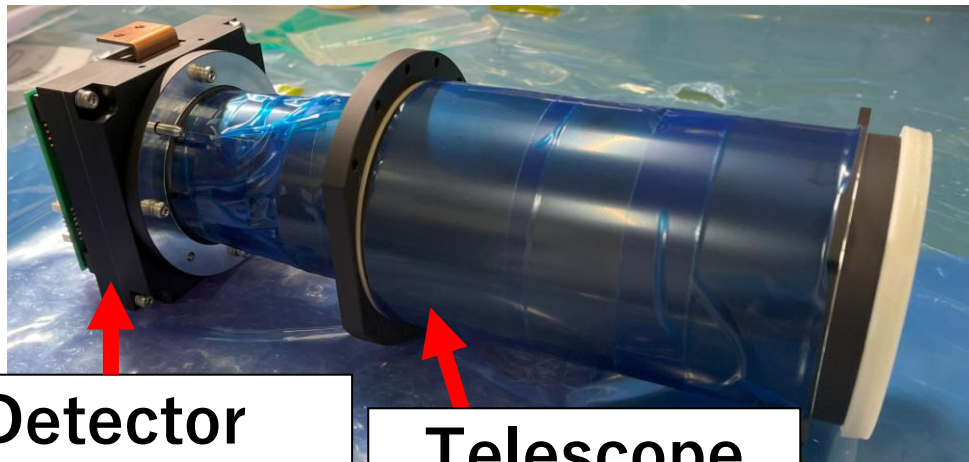
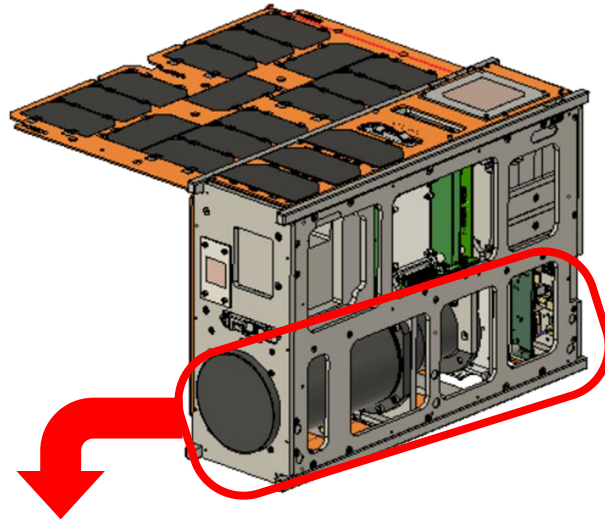

Detector  
CMOS sensor  
installed

Telescope  
 $f = 70\text{mm}$   
F2.0

## Wavelength band

Detector

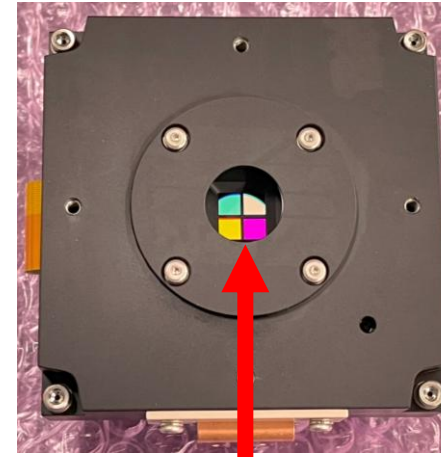

Color Filters

Wavelength band

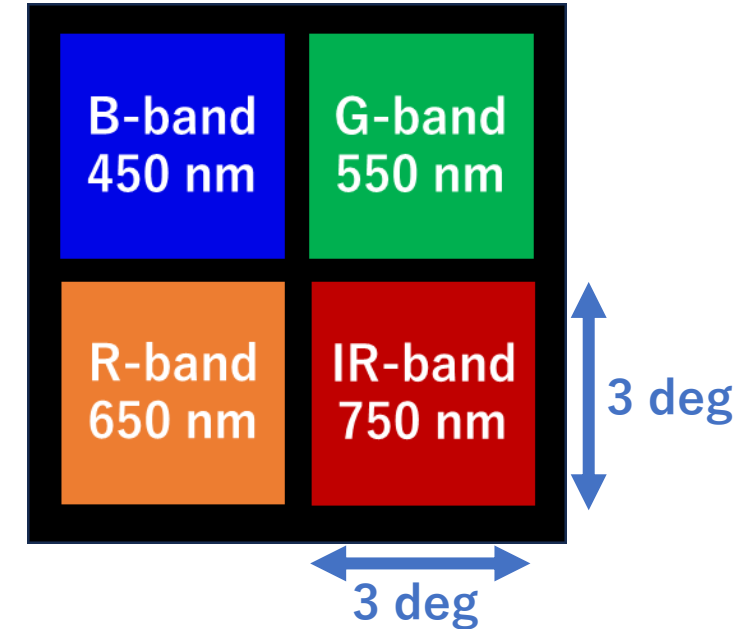

## Feature of the detector

CMOS sensor: SONY IMX533

Effective pixels: 3008 pix x 3008 pix

# 1. Overview of the detector for VERTECS



## Structure of the detector module

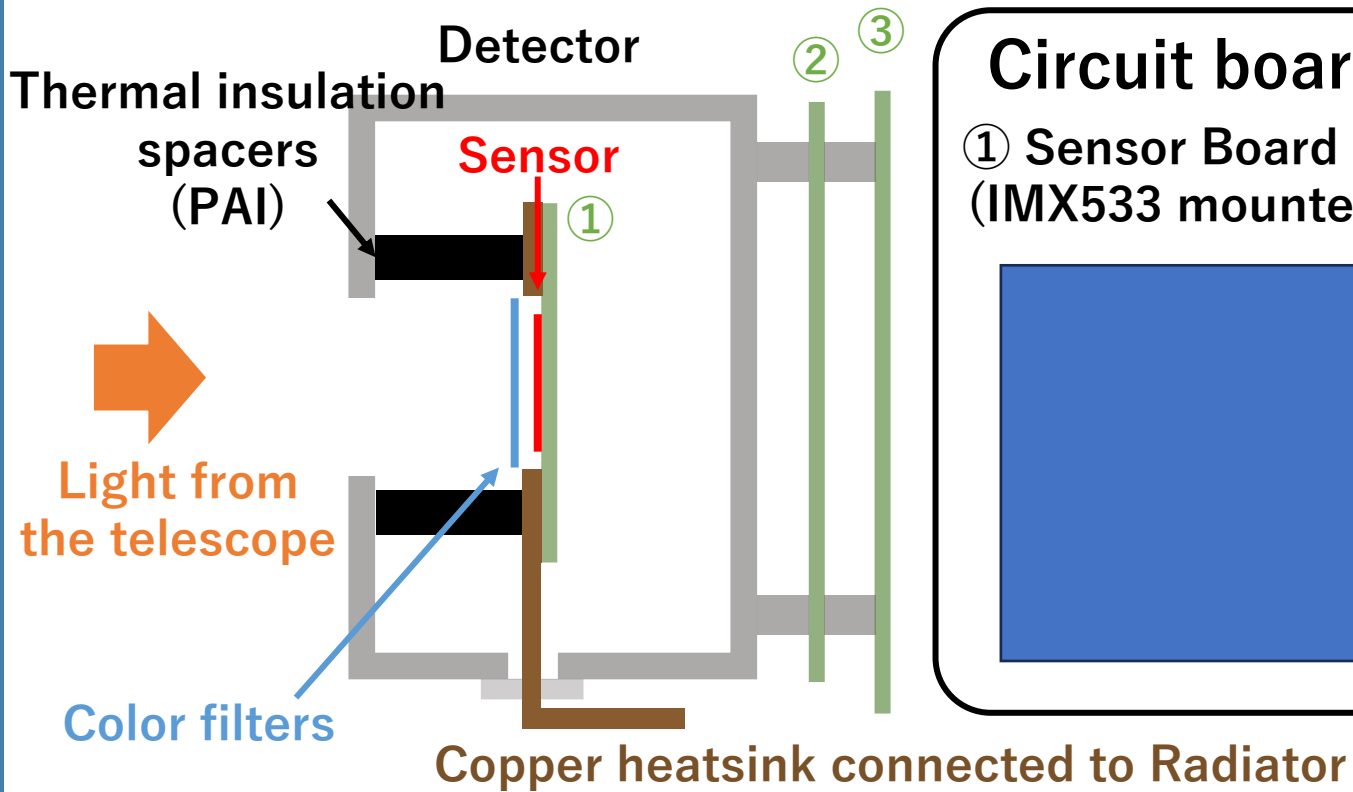

### Circuit boards mounted to the detector

① Sensor Board  
(IMX533 mounted)

② Image Capture  
Board

③ Camera Control  
Board (Raspberry Pi)

※非公開

- Insulate the heat using the thermal insulation spacers, and connect the copper heatsink to the radiator → Cool down the sensor below 0°C
- Data from the sensor: acquired by sending commands from Raspberry Pi

## 2. Purpose of the evaluation



To detect the extragalactic background light (EBL) ( $S/N \geq 10$ )

$10 \text{ nWm}^{-2}\text{sr}^{-1}$

→ High S/N is essential for observing the EBL

- Spectral responsivity including the optical system → Signal
- Shot noise by zodiacal light (ZL) + Detector noise → Noise  
Dark current noise + Readout noise

**Purpose of the evaluation**

**Estimate S/N by measuring**

- 1. Spectral responsivity**
- 2. Detector noise**



**Confirm the possibility of the EBL detection**

# 3. Spectral responsivity evaluation



## Two measurements for deriving spectral responsivity

1. The integrating sphere (IS) measurement  
→ Derive absolute responsivity
  - Detect light from the IS by the detector  
→ Derive the signal electron from acquired image
  - Measure the radiance of the IS using the calibrated spectrometer

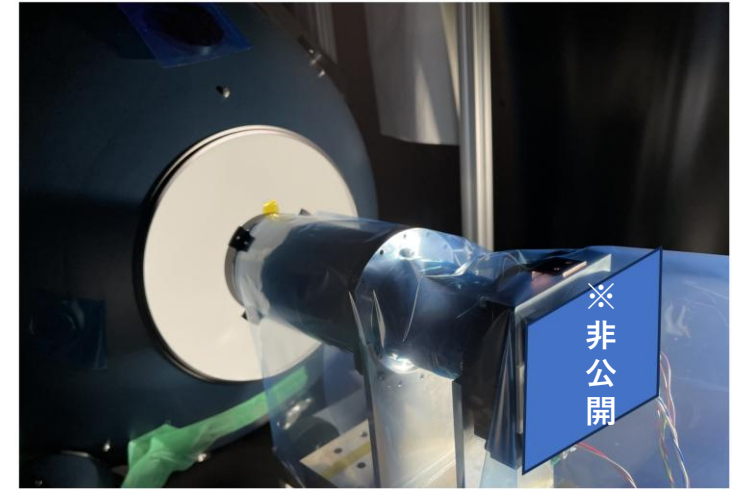

2. The monochromator measurement  
→ Derive spectral response
  - Measure the monochromatic light using the detector and the spectrometer (99 wavelengths from 360 nm to 850 nm)



# 3. Spectral responsivity evaluation



## Result: Absolute spectral responsivity of each band

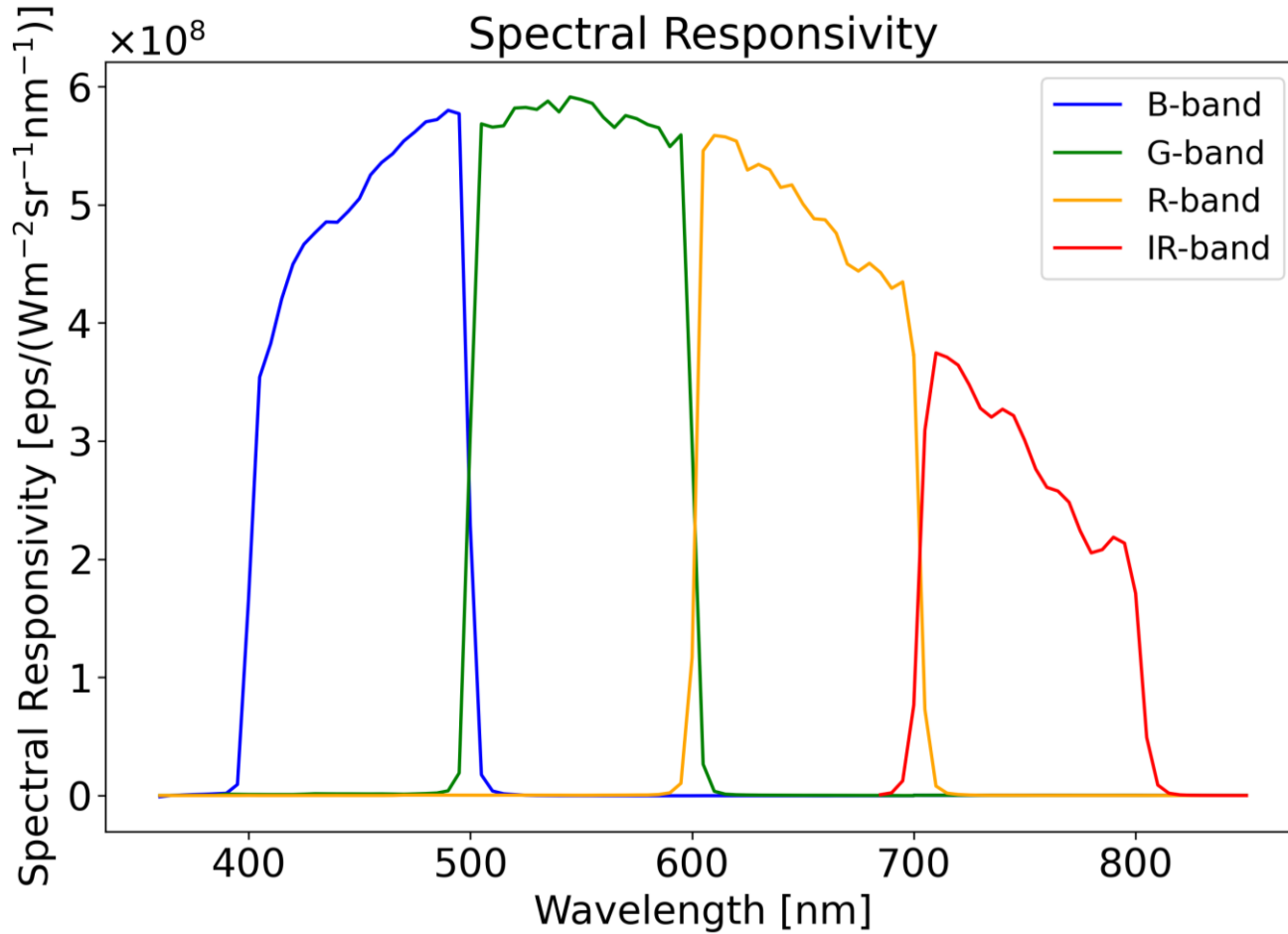

eps: electrons per second  
e: electrons

Signal by the EBL:  $n_{e,EBL}$  [e]

Mean responsivity for each band  
[eps/(Wm<sup>-2</sup>sr<sup>-1</sup>nm<sup>-1</sup>)]

$$n_{e,EBL} = I_{EBL} \times \text{responsivity} \times \tau$$

Surface brightness of EBL [Wm<sup>-2</sup>sr<sup>-1</sup>nm<sup>-1</sup>]

Exposure time [s]

$$\tau = 60 \text{ s}$$

Signal by the EBL (10 nWm<sup>-1</sup>sr<sup>-1</sup>):

- B-band: 0.67 e
- G-band: 0.64 e
- R-band: 0.46 e
- IR-band: 0.24 e

# 4. Detector noise evaluation



## Overview: Dark current and readout noise measurement

Measure the change of the dark current and readout noise when the temperature change

→ Check the detector noise at temperature in the orbit

Below 0°C

**Measurement conditions:**

- Integrate the detector into the satellite
- Place the satellite in the chamber
  - Simulate the vacuum and low-temperature environment in orbit

## Vacuum cooling chamber

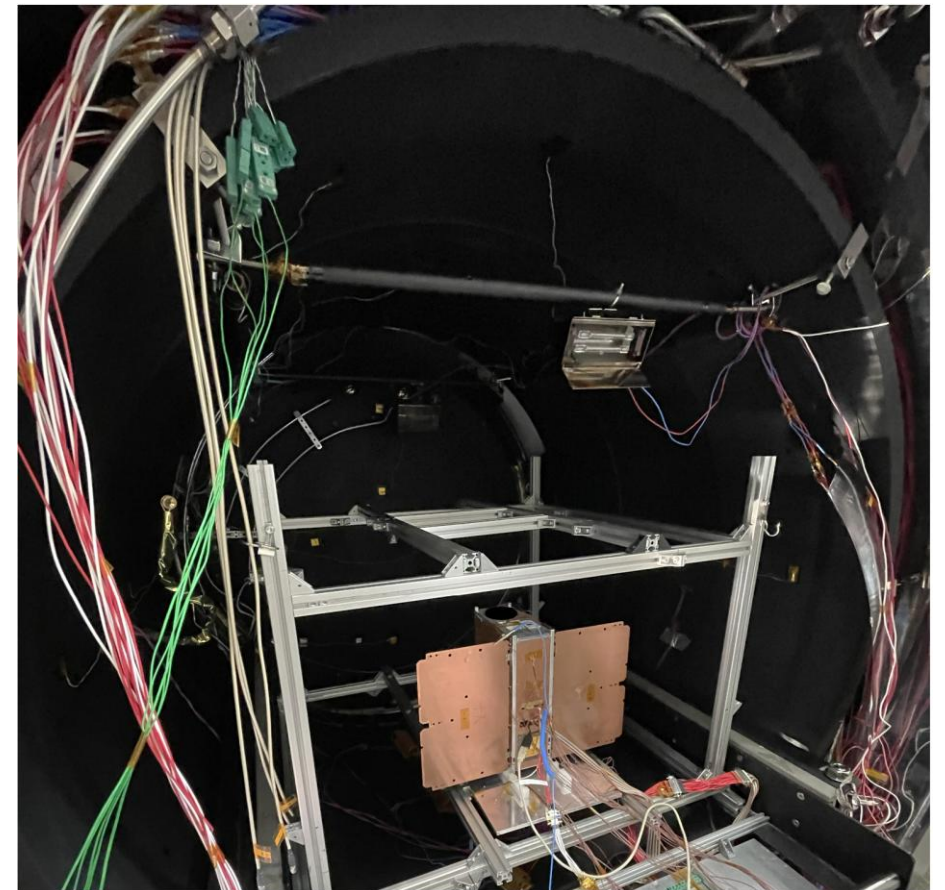

# 4. Detector noise evaluation



## Result: Dark current measurement

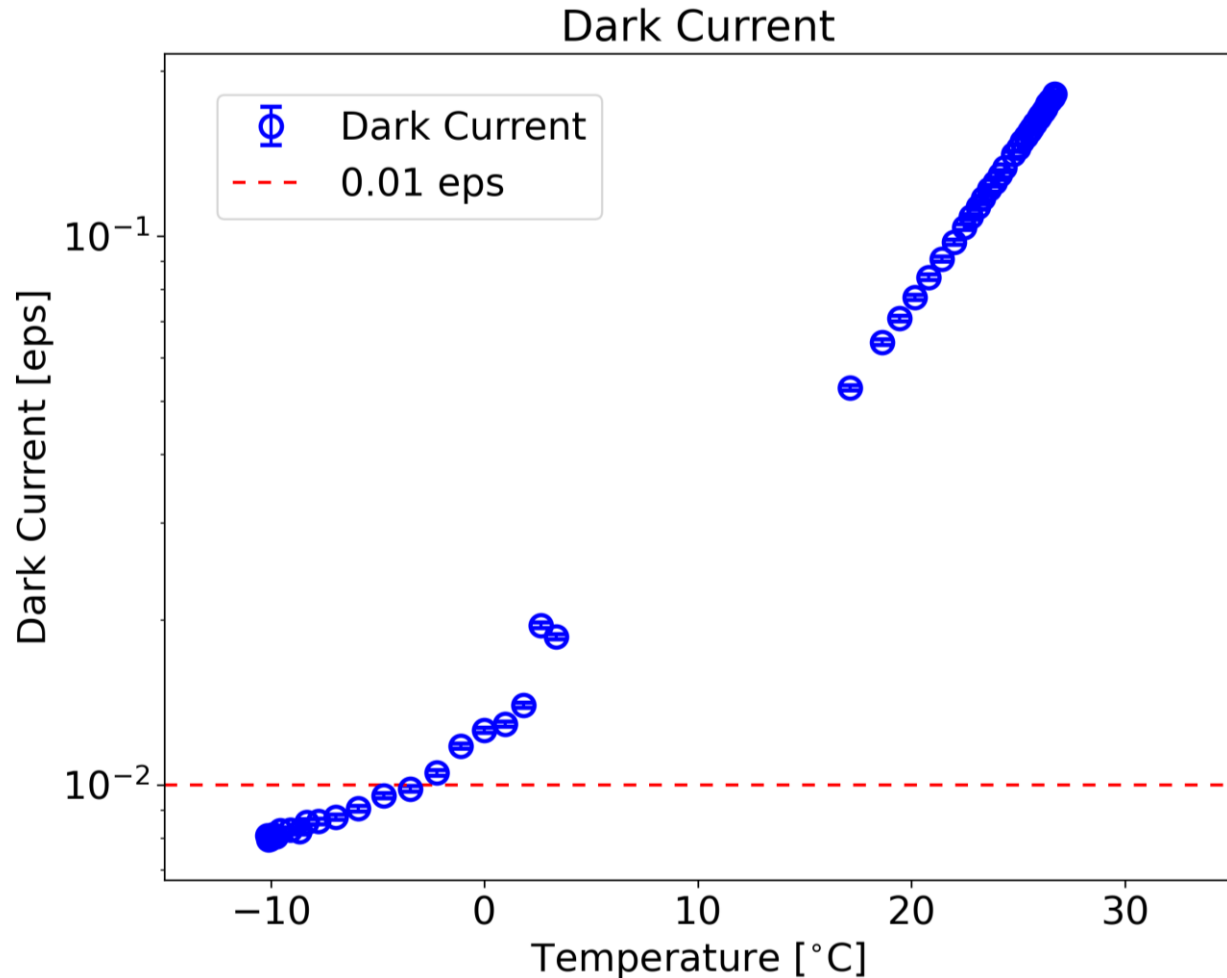

**Dark current: below 0.01 eps  
at ~0°C**

$$\text{Dark Current Noise} = \sqrt{\text{Dark Current}}$$

**Dark current noise at ~0°C  
→ Below 0.8 e  
(Exposure time: 60 s)**

# 4. Detector noise evaluation



## Result: Readout noise measurement

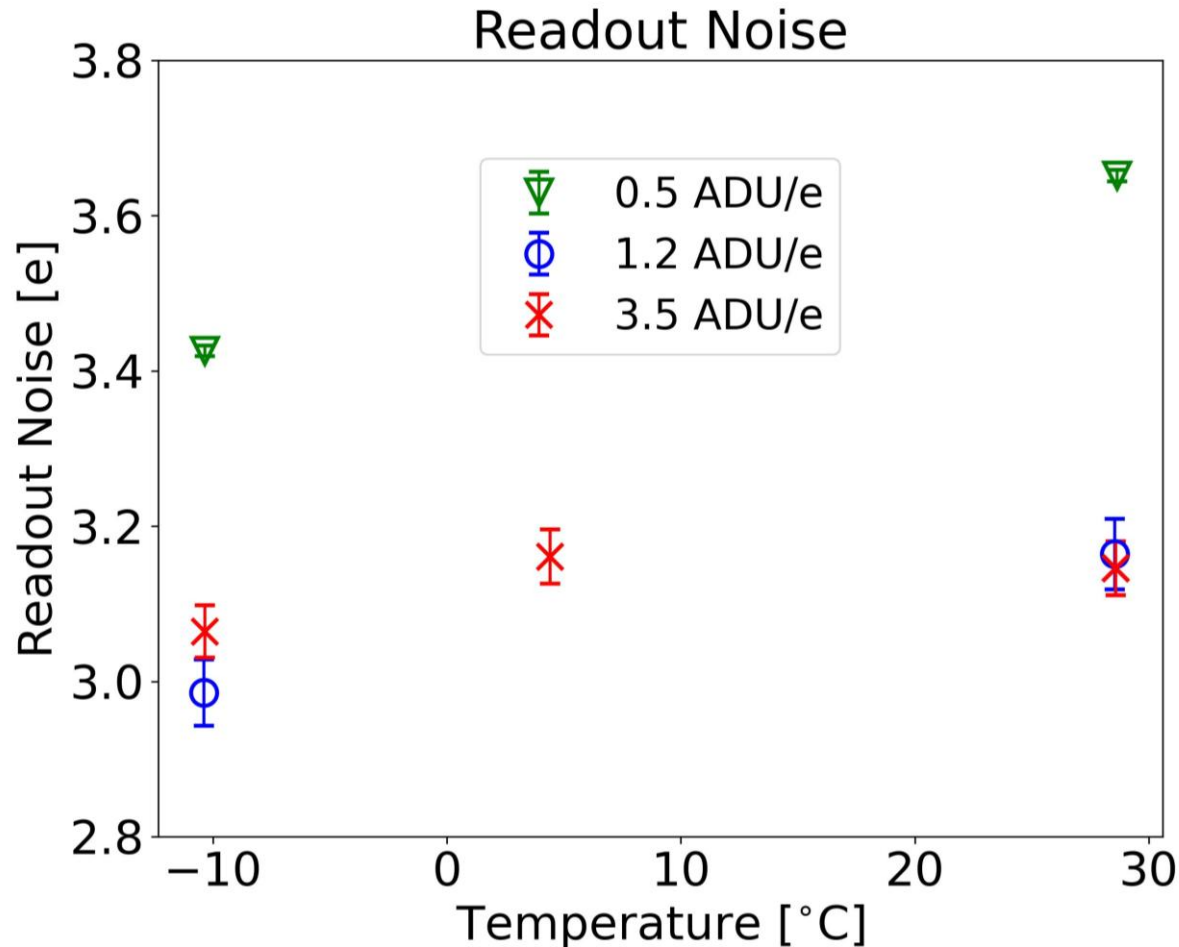

Detector noise at  $\sim 0^\circ\text{C}$

- Readout noise : 3.0 e (1.2 ADU/e)
  - Dark current noise  $\leq 0.8$  e (Exposure time: 60 s)
- Detector noise  $\leq 3.1$  e

**Noise including the shot noise by the ZL:**

- $N \leq 9.8$  e (B-band)
- $N \leq 9.6$  e (G-band)
- $N \leq 7.8$  e (R-band)
- $N \leq 5.7$  e (IR-band)

**when the surface brightness of the ZL is  $900 \text{ nWm}^{-2}\text{sr}^{-1}$  at 750 nm**

# 5. S/N estimation



From the performance evaluation results, estimate S/N for each wavelength band when observing the EBL (Exposure time: 60 s)

Wavelength band	Signal electrons per pixel	Noise electrons per pixel	Total S/N for 0.5M pixel average
B-band (450 nm)	0.67 e	$\leq 9.8$ e	$\geq 48$
G-band (550 nm)	0.64 e	$\leq 9.6$ e	$\geq 47$
R-band (650 nm)	0.46 e	$\leq 7.8$ e	$\geq 42$
IR-band (750 nm)	0.24 e	$\leq 5.7$ e	$\geq 30$



**The EBL can be detected at  $S/N \geq 30$  by averaging 0.5M pixels, equivalent to half the number of pixels in each band.**

# 6. Future prospects



- Monitor the mean responsivity for each band by observing standard stars
- Monitor the detector noise using the filter mask region in orbit (Including the radiation effect)

Color filters

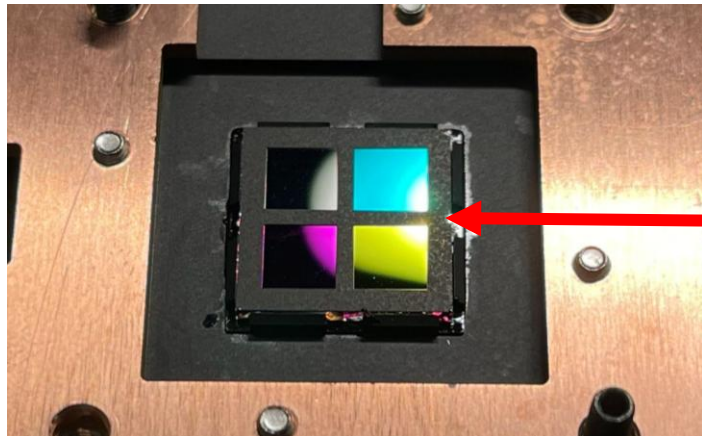

Filter mask region

