

Test observations and Performance Evaluation of a Wide-Field, High-Speed CMOS Camera on the 90-inch Telescope at the University of Arizona

2025/11/10

Hosei University

Mihiro Takahashi

Yutaka Komiyama, Kotaro Tsuchiya, Mai Murakami(Hosei Univ.), Yukiko Kamata, Satoshi Kawanomoto,
Michitaro Koike, Satoshi Miyazaki(NAOJ), Yutaka Fujita(Tokyo Metropolitan Univ.),
Masamune Oguri(Chiba Univ.), Eiichi Egami(Univ. of Arizona)

Introduction

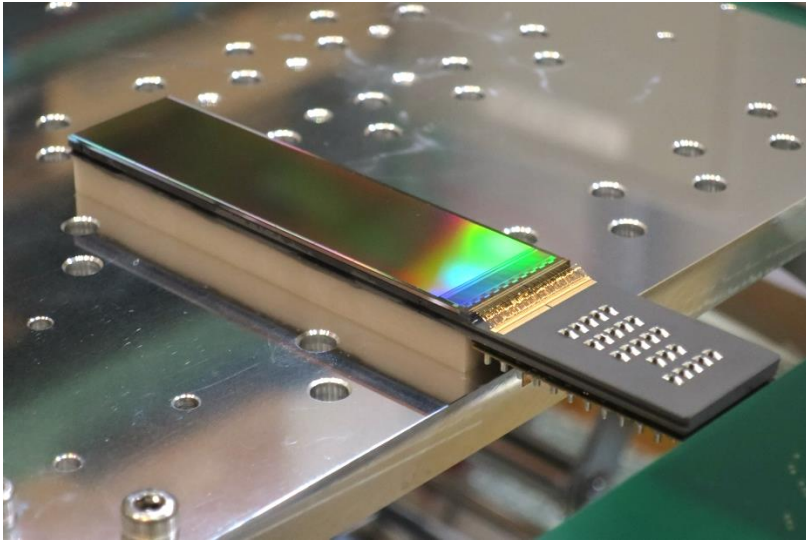

New CMOS Sensor for Astronomical Observations developed by NAOJ & Hamamatsu Photonics

- ✓ High sensitivity & wide dynamic range
- ✓ High-speed readout
 - Full frame: 10 frames/sec
 - Partial : 1000 frames/sec (Max)
- ✓ Large format
 - 2560 × 10000 pixels

CMOS sensor:

Capable of **faster readout** compared to conventional CCD sensors

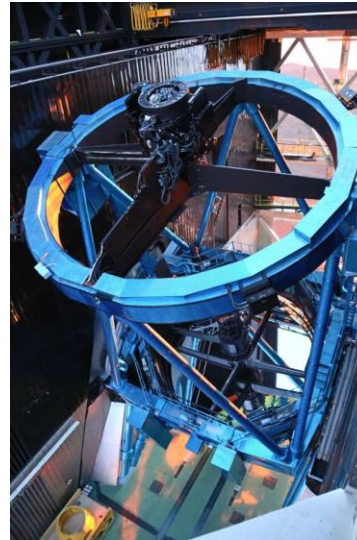

When installed on the Subaru Telescope ...

- ✓ Large light-gathering power
- ✓ High resolution
- ✓ Wide-field prime focus optical system



**Pioneering a New Generation of Wide-Field,
High-Speed Astronomy!!**

★ Purpose

Conduct test observations with the University of Arizona 90-inch telescope to **evaluate the performance of the CMOS camera**.

→ Laying the foundation for its installation on the Subaru Telescope.

Methods : mechanical development

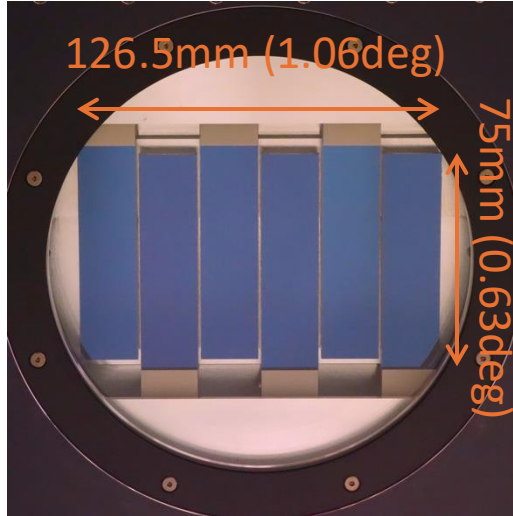

- The camera is equipped with **six CMOS sensors** aligned in a single row.
- Its field of view is approximately equivalent to four full moons.
- **Maintaining a vacuum and cooling(-50°C) inside the dewar** is essential.
 - The sensor temperature rise → thermal noise is generated
 - Cooling under atmospheric pressure → condensation occurs due to water molecules
- To cool the system, **liquid nitrogen** is used.
- Cooling is achieved through metal components called **heat path** and **cold plate**.

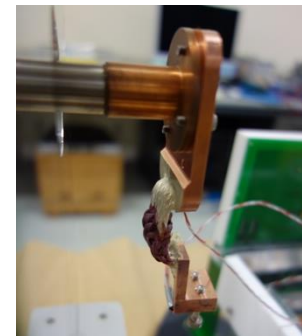
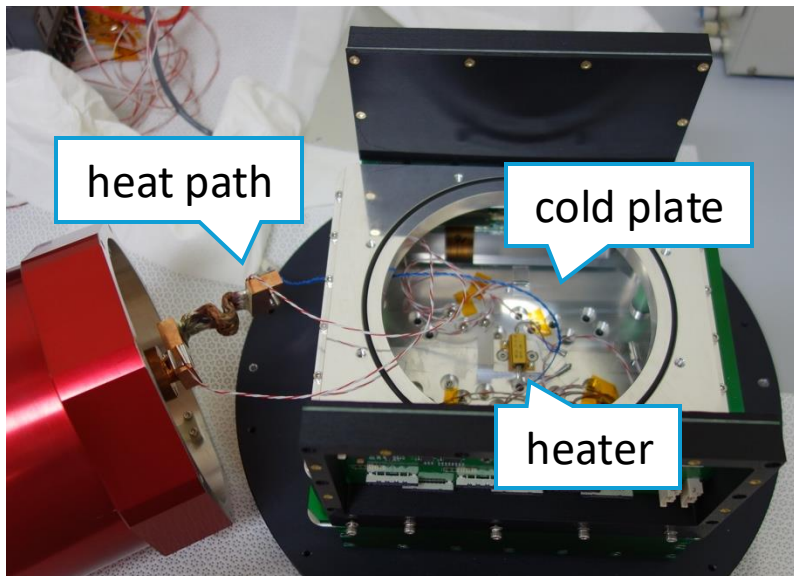
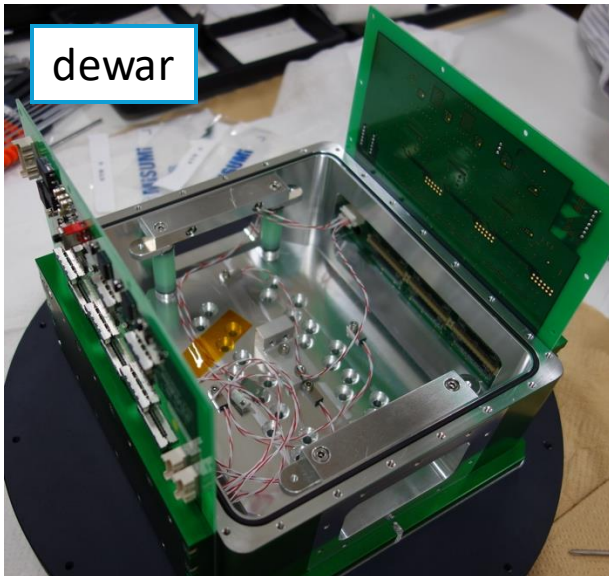

The design was optimized considering thermal conductivity and ease of assembly.

- To prevent overcooling, **a heater and eight temperature sensors** were installed inside the dewar, allowing continuous monitoring and active temperature control.

Methods : mechanical development

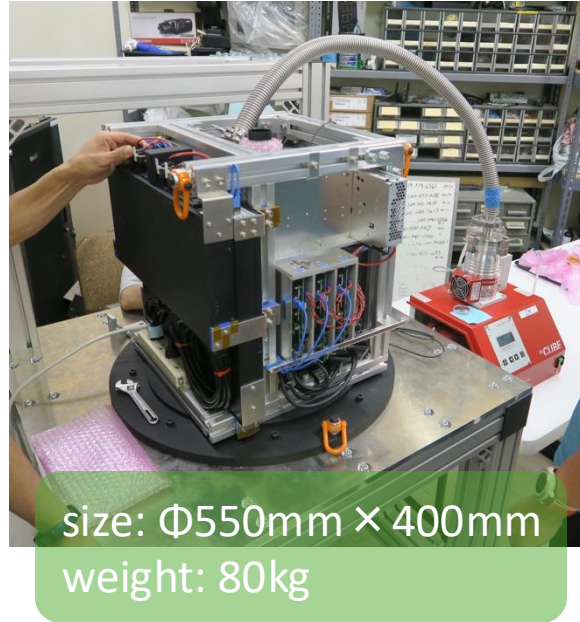
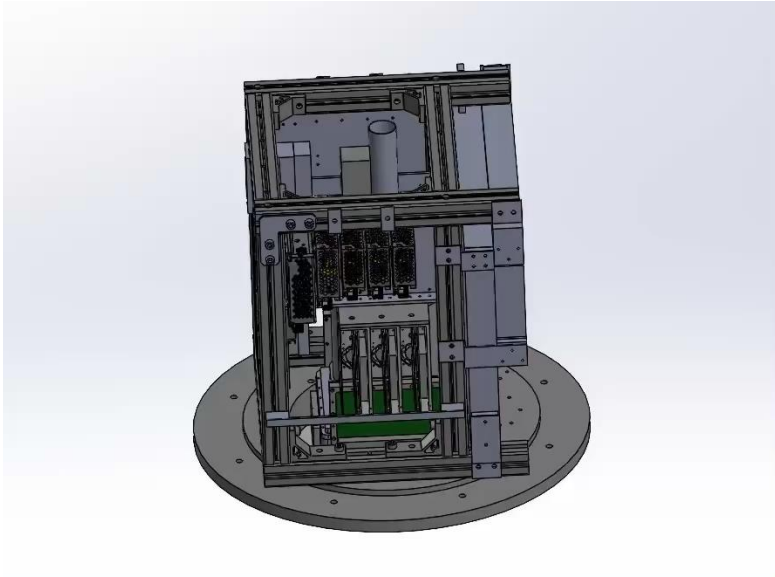

- A camera requires a lot of equipment. (power supplies, network switches, etc.)
- Since **the camera is installed at the prime focus**, careful weight distribution and a compact design are required.
 - Using 3D CAD, we examined where to place each piece of equipment and devised methods for securing them.
- When installing the camera at the prime focus, **it is tilted by about 15 degrees** and lifted using a lifting zig.
 - An original cart was designed for camera assembly and installation.
 - Frame length calculated and wheels providing adjustable movement as needed.

Methods : observing plan

<Performance Evaluation Items>

- **Optical Alignment** : Adjustment of the focus and optical axis between the telescope and the CMOS camera
- **Throughput** : Evaluation of the telescope's light-gathering efficiency and wavelength sensitivity characteristics
- **PSF Time Variability** : Investigation of how the PSF changes with exposure time
- **Image Quality** : Verification of whether each CMOS sensor can produce uniform stellar images
- **Clock Accuracy** : Evaluation of the precision of the camera's internal clock

<Objects>

- **Photometric standard stars** (BD284211, GD248, GD50)
The brightness is stable and measured with high precision.
→ Suitable for sensitivity evaluation.
- **Globular clusters** (M39, M2, M71)
Region with a high density of stars.
→ Appropriate for focus adjustment and image quality assessment.
→ Also suitable for **lucky imaging**.

Transmission curves of the SDSS filters used on the 90-inch telescope

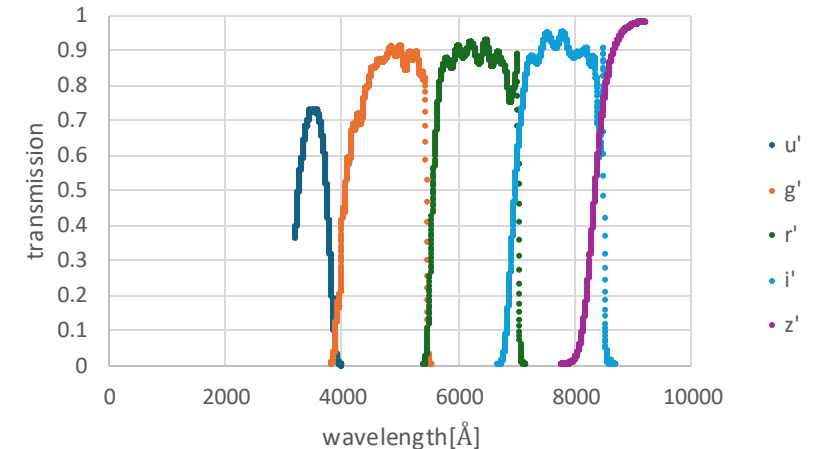

By capturing a large number of short-exposure images of an object and selecting and combining the sharpest frames, higher-resolution images can be obtained.
→ This technique reduces the effects of atmospheric turbulence.

Results : test observations

- Due to the delayed arrival of the cargo, the planned 7 nights of observation were reduced to 3.
⇒Owing to weather conditions and filter wheel issues, 3 nights were reduced to 1.
- However, no technical issues occurred with the CMOS camera, and **we were able to achieve first light!**

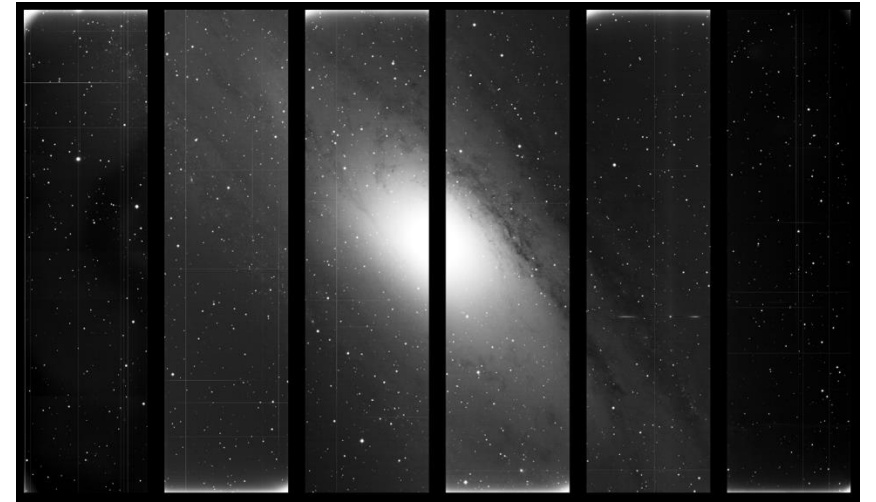

First Light of CMOS Camera (M31)

- Not all of the planned targets were observed.
- I will use the data obtained from the photometric standard star BD284211 for **sensor alignment within focal plane.**

Results : astrometric calibration

○ : stars from Gaia DR3
○ : stars detected on the sensor

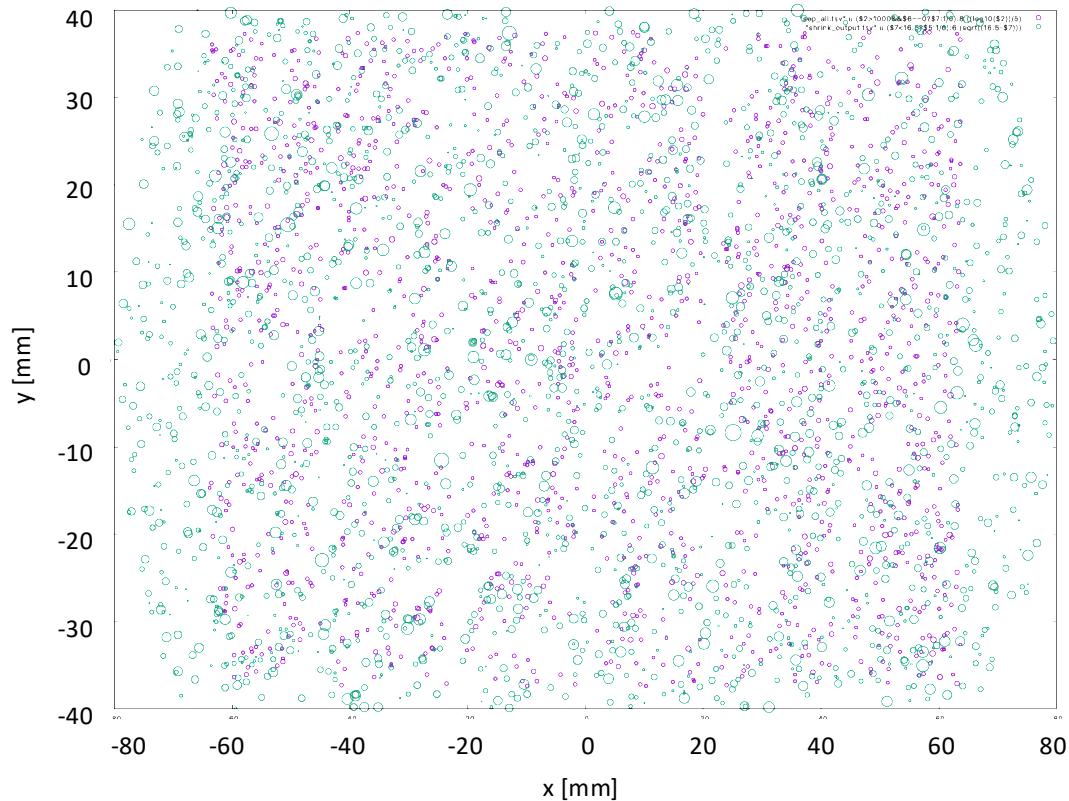

Plot showing stars from Gaia DR3 and those detected on the sensor overlaid on the same coordinate system.

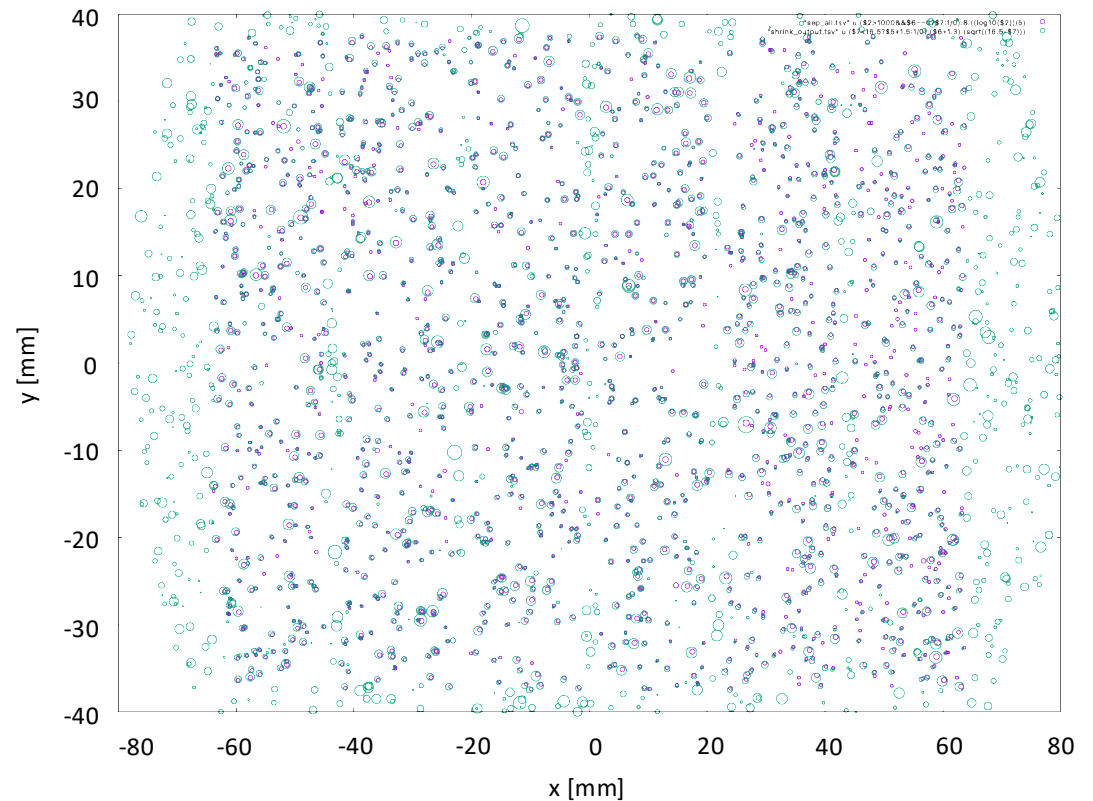

Plot where +1.5 was added to the x value and +1.3 to the y value of the Gaia DR3 stars.

- As shown in the right figure, adding arbitrary offset values results in an approximate match between the Gaia DR3 stars and those detected on the sensor.
- This offset arises from both the camera's positional misalignment during telescope installation and the telescope's pointing error, though the two effects cannot be distinguished.

Results : astrometric calibration

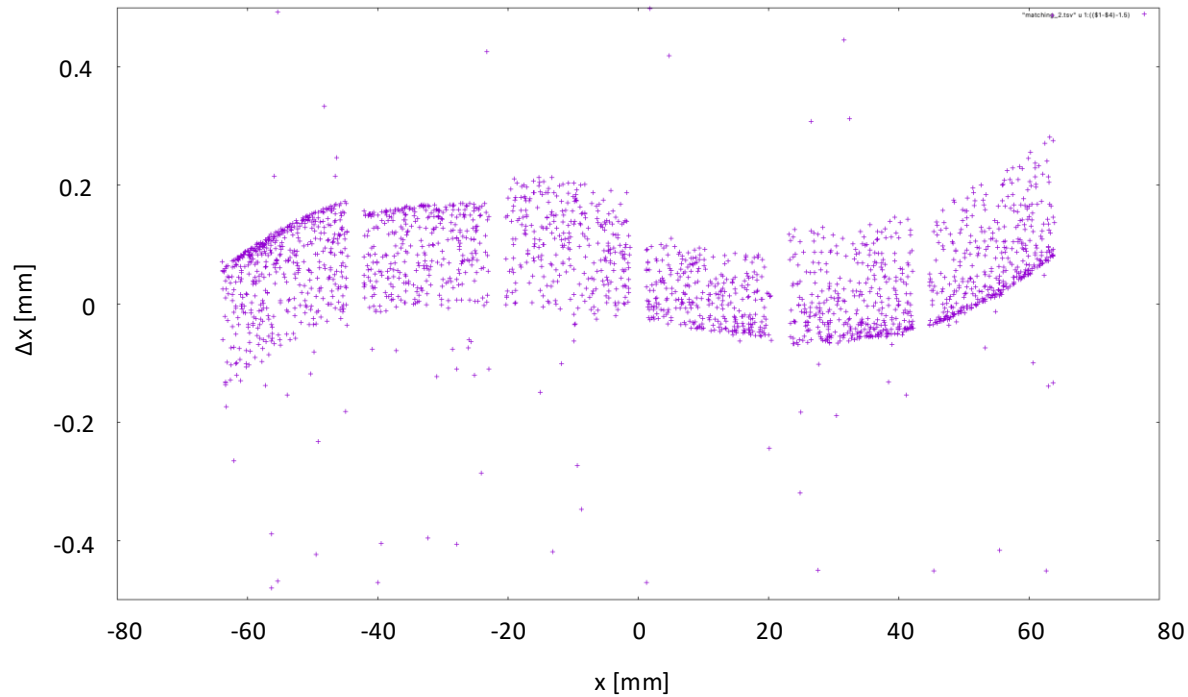

Plot of the residuals between the x value of stars detected on the sensor and those from Gaia DR3.

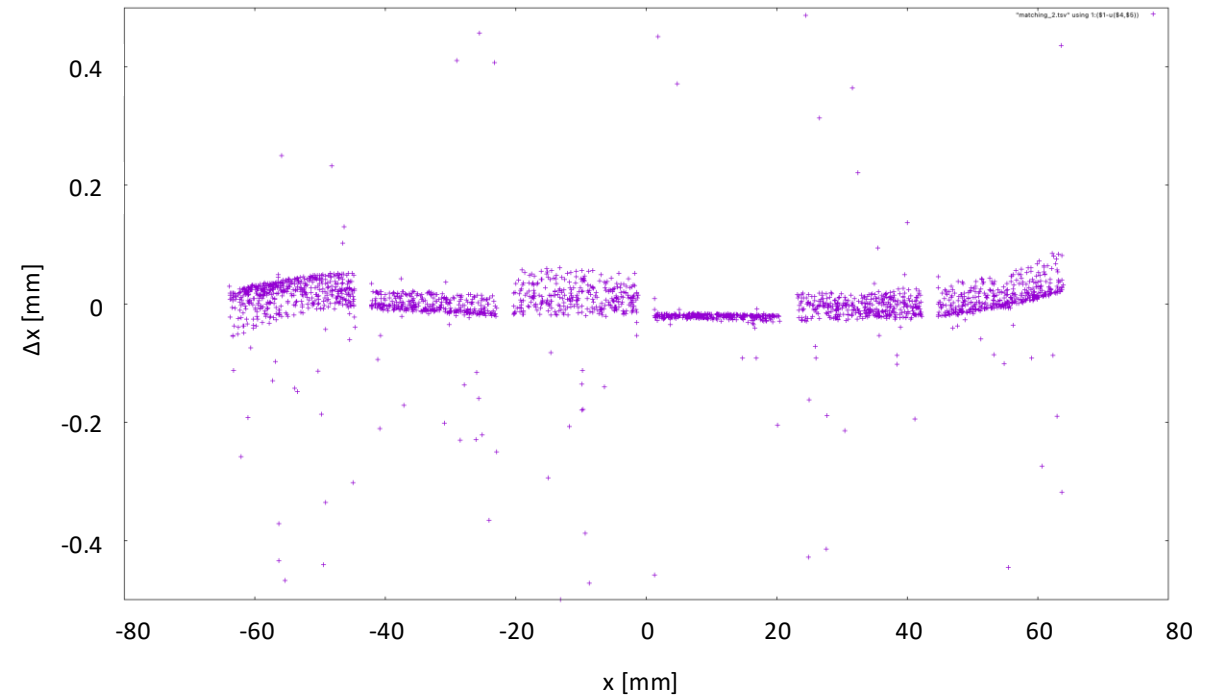

Plot after fitting with a 5th order polynomial.

- The vertical axis represents the residuals of the x value.
- Since the positional offsets show a positive cubic-like trend, **it suggests the presence of a pincushion distortion component in this optical system.**
- After fitting with an odd-order polynomial up to the 5th order, the residuals were found to be generally reduced.
- Further reduction in the residuals is expected after correcting for the relative positions and rotations between the chips.

Summary

- Test observations conducted with the new CMOS sensor using the 90-inch telescope at the University of Arizona.
- Designed various instruments and developed software in preparation.
- Successfully achieved its first light, though limited data were obtained.
- Using imaging data of the photometric standard star BD284211, I will continue astrometric calibration to clarify the positional offsets of the CMOS sensors.
- Next observation run scheduled for January to further evaluate performance and pursue scientific results.

Appendix

Schematic Hardware Configuration

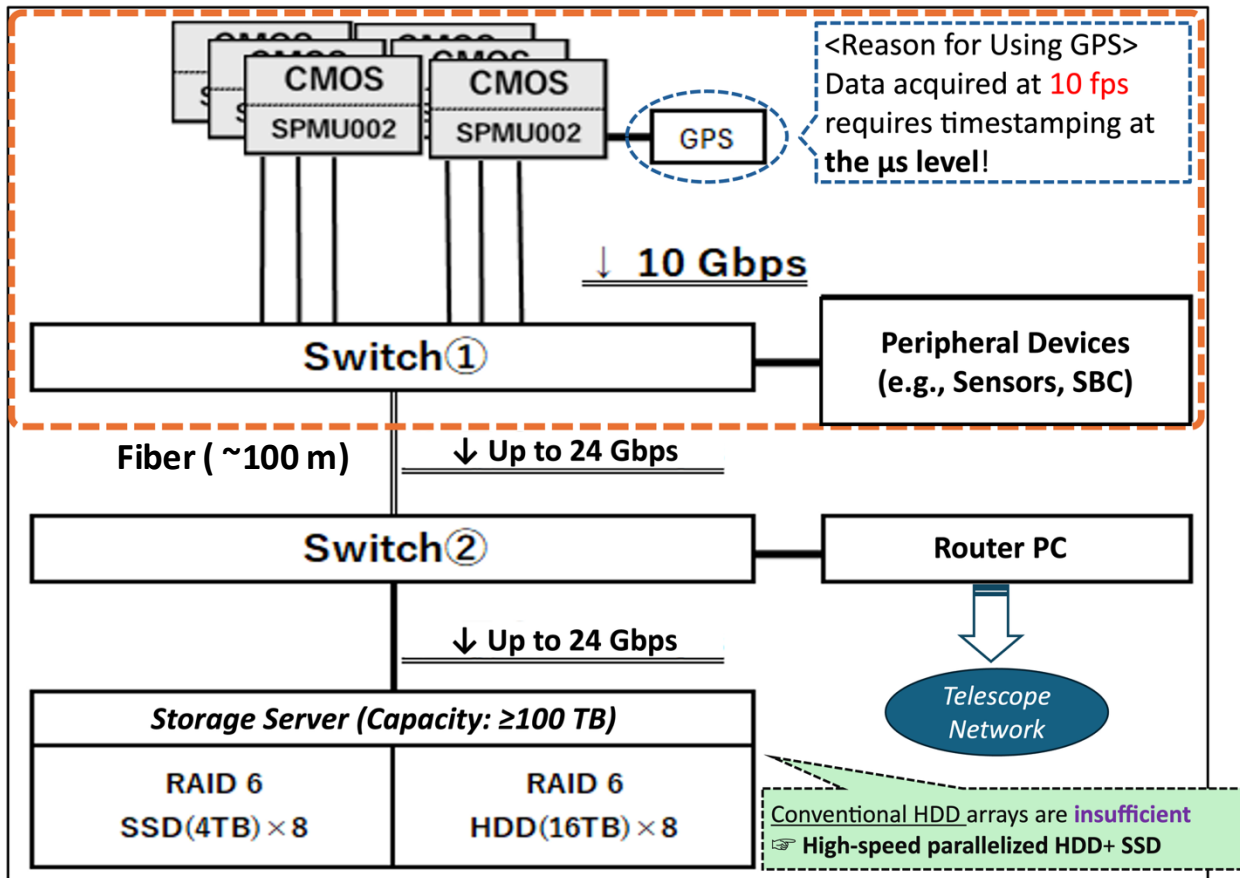

High sensitivity and fast readout of CMOS sensors demand:

- ▶ High-throughput data transfer (up to 3 GB/sec)
 - ▶ Large-volume data storage
- A storage system with **high-speed writing** and **large-capacity recording** is essential!

< Observation Conditions & Data Volume >

- Image size per frame: 50 MB
- Frame rate (10-bit): 10 fps
- Observation duration: ~ 8 hours \times 7 days
- Data rate: $50 \text{ MB} \times 10 \text{ fps} \times 6 = 3.0 \text{ GB/sec}$
- Total data (1 week, 8 hours/day):
 $3.0 \text{ GB/sec} \times 201,600 \text{ sec} \approx \mathbf{600 \text{ TB}}$



For this test observation, we prepared **100 TB** as the minimum storage requirement.