

National Institutes of Natural Sciences
Astrobiology Center

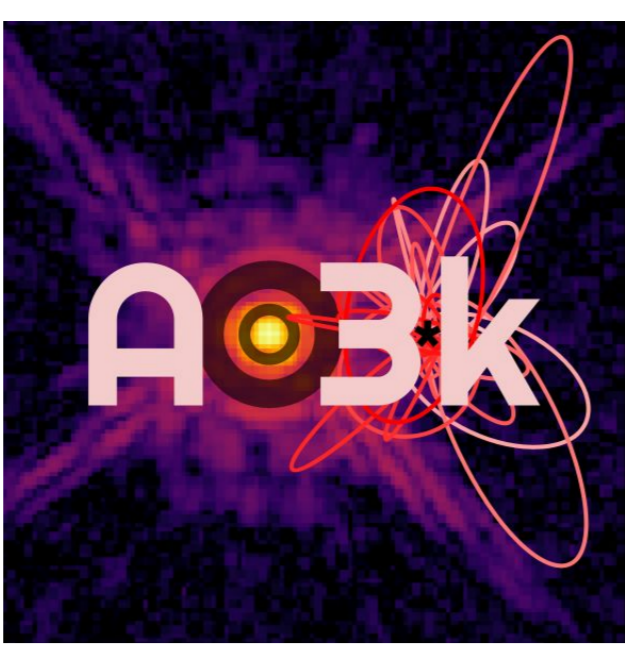

Korea Astronomy and Space Science Institute



Updates on AO3k's new modules

Julien Lozi^{1,2}, Kyohoon Ahn^{3,1}, Vincent Deo^{4,1}, Olivier Guyon^{1,2,5,6}, Takashi Hattori¹, Sandrine Juillard^{1,5}, Shogo Nishiyama⁷, Yoshito Ono¹, Garima Singh^{1,2}, Yuhei Takagi¹, Sébastien Vievard^{8,9,1}

1. National Astronomical Observatory of Japan - Subaru Telescope, 2. NINS Astrobiology Center, 3. Korea Astronomy and Space Science Institute (KASI), 4. Optical Sharpners, France, 5. Steward Observatory - University of Arizona, 6. College of Optical Sciences - University of Arizona, 7. Miyagi University of Education, 8. Space Science and Engineering Initiative, College of Engineering, Institute for Astronomy, University of Hawai'i, 9. Institute for Astronomy, University of Hawai'i

I. AO3k Polychromatic Calibration Source

AO188's calibration source AOCAL uses three laser diodes. One at 633 nm (red), one at 1550 nm (IR), one a 589 nm (sodium wavelength). It does not include a pupil mask, but has two wheels simulating atmospheric turbulence.

The upgrade of AO188 to AO3k includes:

- new 3000-actuator deformable mirror (DM3k)
- new Near Infrared Wavefront Sensor (NIRWFS)
- new non-linear Curvature Wavefront Sensor (nCWFS).

AO3k's performance is vastly superior to AO188, but it requires a precise calibration of its wavefront sensors.

A new source with the following characteristics is needed:

- Polychromatic instead of laser diodes, with the use of a supercontinuum laser (same as SCEAO's source). This will allow to test the polychromatic mode of the nCWFS (dichroic beamsplitter used), and include chromatic effects in the calibration of the NIRWFS.
- A pupil mask simulating Subaru's pupil. The lack of pupil mask in the current source is creating a sub-optimal response for the calibration of the wavefront sensors. The pupil mask can be fixed, and rotation can be performed with the image rotator.

The same source can also be used by science instruments downstream (IRD, IRCS, SCEAO and its modules, etc) for alignment, focusing, mapping and other characterization during daytime testing.

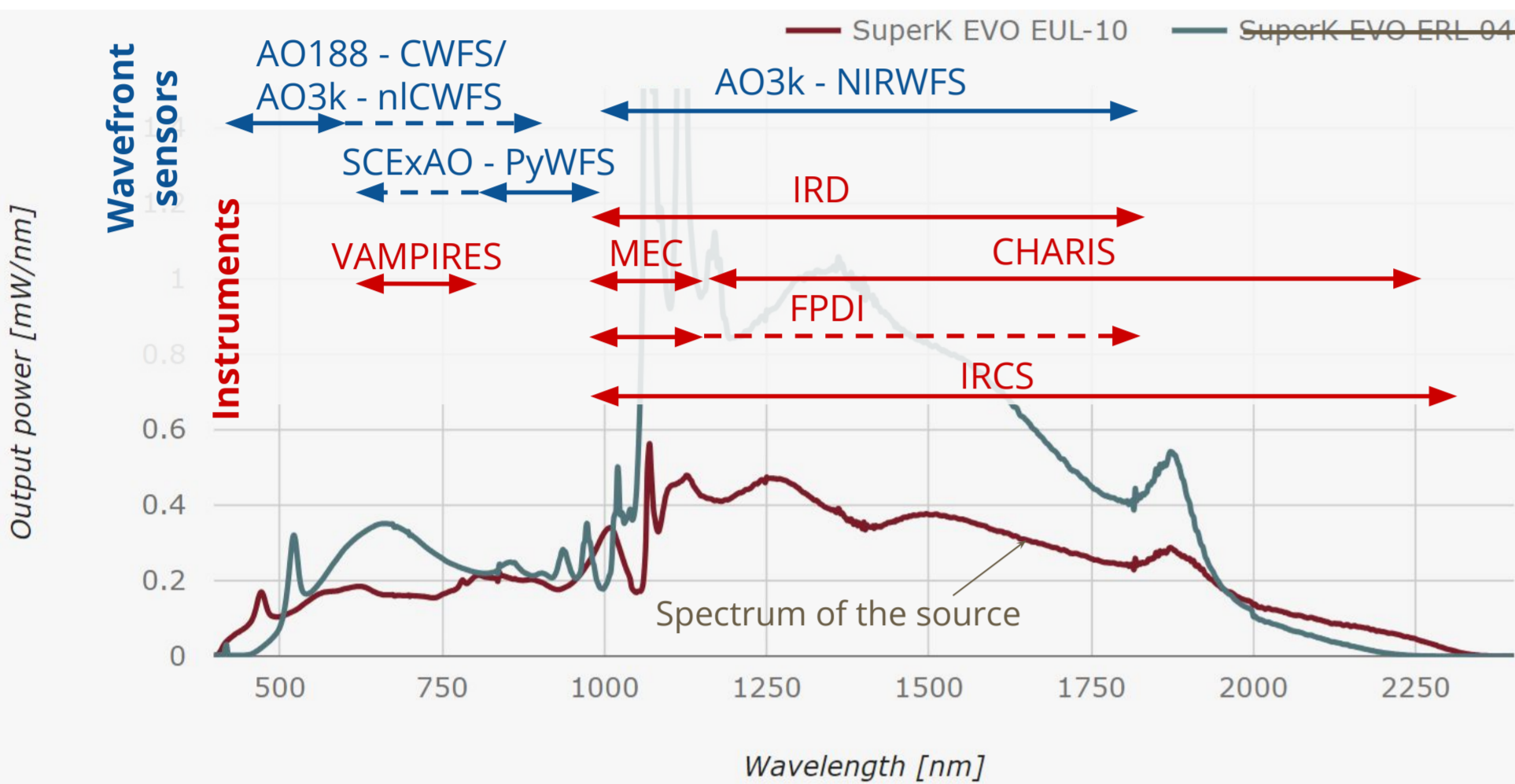

Due to the large wavelength coverage of the polychromatic source, the optical design is based on off-axis parabolas (OAP) and flat mirrors.

- Since the focal plane is inside the image rotator, the OAP's focal length has to be large enough to clear the IMR, but short enough to have a reasonable beam size for the f/13.9 beam. The only off-the-shelf solution is the Thorlabs MPD2151-P01. It has a 2" diameter, a 381 mm focal length, and 15 degrees of off-axis angle. With this focal length, the beam diameter is 27.4 mm.
- The source is collimated by OAP 1, then through a series of fold mirrors, the collimated beam goes through a pupil mask at a distance f_{OAP1} and the focusing OAP 2 at a distance $2f_{OAP1}$.
- 3 fold mirrors are necessary to fit in the available space. Fold 3 is designed to be as close as possible to the IMR, and due to the shallow angle of the OAPs, the beam reflects close to the edge of the mirror.
- The OAPs are oriented in such a way so that they compensate for each others astigmatism.
- Moving the fiber in X and Y allows a range of $\pm 20^\circ$ vertically and $\pm 3.6^\circ$ horizontally, due to the position of Fold 3. But by moving all the components horizontally instead, we can get a range of $\pm 22.5^\circ$ horizontally.
- The optical quality is almost perfect over the whole range of wavelengths and all positions in the field.

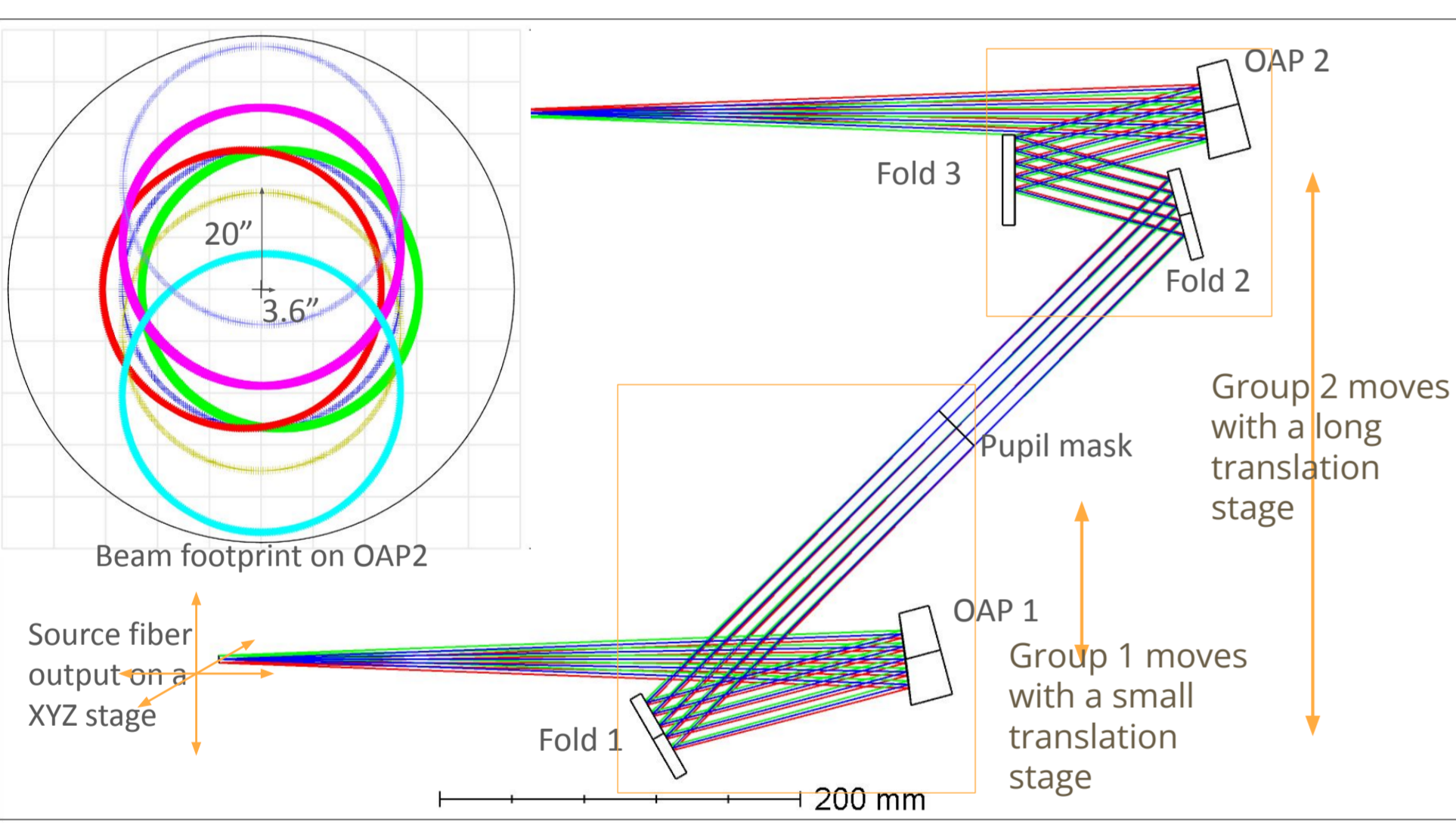

Zemax optical design. The optics are grouped in two groups that will not collide when the source is retracted. Each group is motorized on one axis separately, and the fiber itself is on a separate XYZ stage.

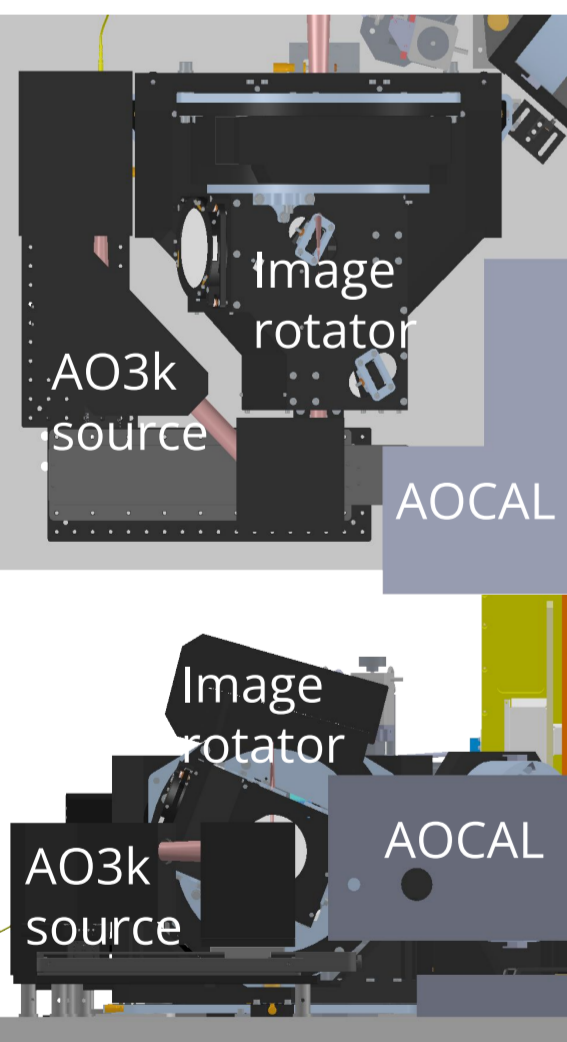

The mechanical design has to fit inside a L-shaped footprint next to the image rotator, and take into account the motion of AOCAL when it is used or retracted.

- It is using off-the-shelf parts as much as possible. Two 150x450 mm raised plates arranged in a L shape constitute the base. A 300 mm OptoSigma translation stage is used for group 2, while a Thorlabs 25 mm translation with a Zaber motor moves group 1. The source uses a Thorlabs 3-axis 25 mm stage, also powered by 3 Zaber motors.
- The three optics of group 2 are attached to a 150x150mm plate, while the three optics of group 1 are attached to a custom plate. OAPs are mounted in fixed custom mounts, while the others are mounted in off-the-shelf adjustable holders.
- When the original source is retracted, the new source can be inserted by moving group 2 in front of the image rotator.
- Interlocks are necessary for the operation of both sources: one can only be used if the other one is retracted completely.
- The design includes baffles to avoid any stray light when in use.
- Clearances were checked to avoid any collisions with the IMR and AOCAL when they are in motion.

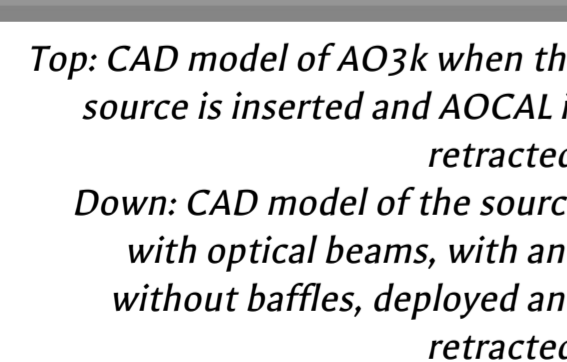

Top: CAD model of AO3k when the source is inserted and AOCAL is retracted. Down: CAD model of the source with optical beams, with and without baffles, deployed and retracted.

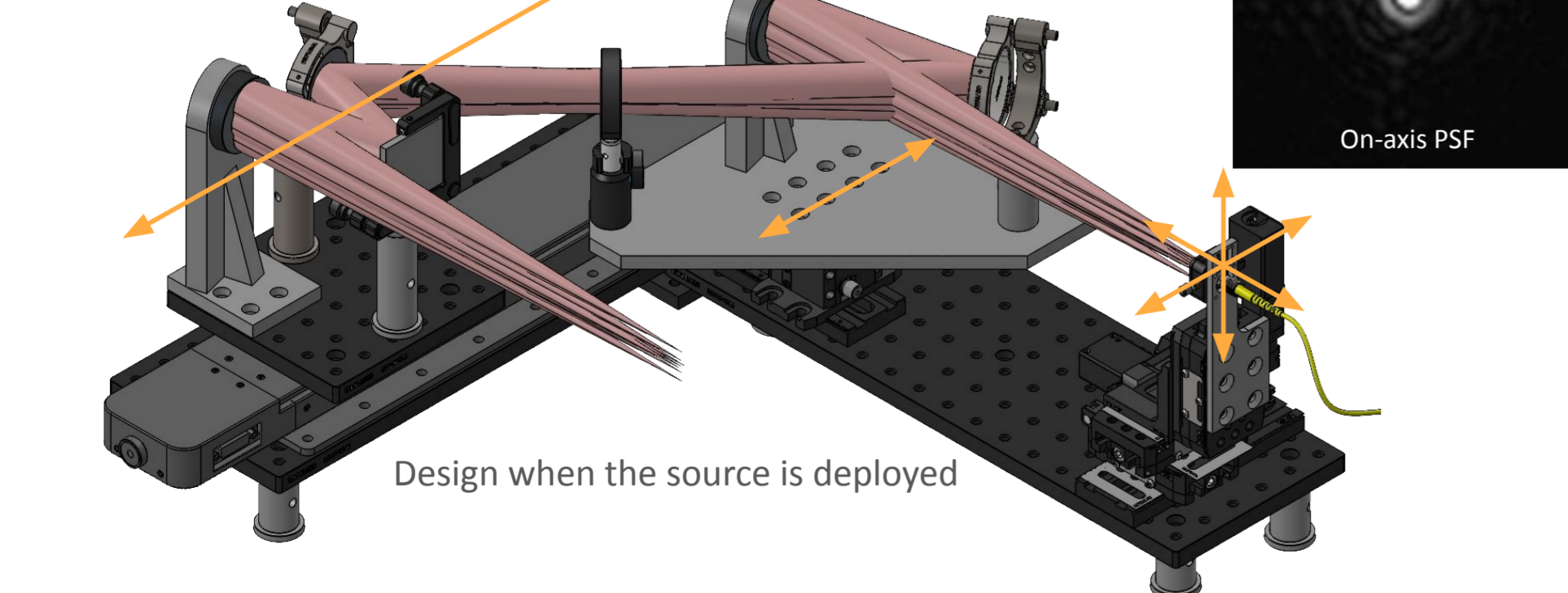

The source was installed in AO3k in summer 2025. Both software and hardware interlocks were put in place to avoid potential collisions with AOCAL. The light used comes from SCEAO's supercontinuum laser, thanks to a rotating mirror selecting which instrument to inject the light to.

The source is now used to calibrate wavefront sensors (NIRWFS, nCWFS), and to check the alignment of the instruments behind AO3k and the NBS. It was very useful for the alignment of SPIDERS behind the NBS, as they needed to clock their pupil masks precisely to match SCEAO pupil rotation.

The source will be used to help get a better flattening of the AO3k deformable mirror, which should improve the static speckle floor in high-contrast images.

II. AO3k - NIRWFS: ON-SKY RESULTS

The NIRWFS v1 was installed in AO188 in 2023. We started Open-Use observations in S24A, with the original 188-actuator DM.

The new ALPAO 3000-actuator DM was installed in May 2024. With the new DM the NIRWFS provided ExAO-level of correction right away.

The first on-sky results from AO3k using the NIRWFS showed very high quality images.

- Data was taken simultaneously with VAMPIRES and CHARIS for analysis.
- CHARIS results showed very high Strehl in J, H and K-band, even for high airmass targets.
- The second level of correction from SCEAO improves even further the Strehl, but mostly improves the stability of the speckle halo around the star. In good seeing conditions, the image looks very similar to the internal source!
- The NIRWFS with the DM3k shows better correction in bad seeing as well, up to 2".

A current limitation showed during those tests is the lack of sensitivity to petalling/island modes, i.e. the modes defined by the 4 quadrants of the pupil. Too often, even in good conditions, the PSF splits into 2 to 4 lobes due to these modes. Several efforts are in progress to improve this issue.

The NIRWFS showed good performance with IRCS as well, despite the lack of ADC. Observations of the galactic center are vastly improved compared to the LGS mode, as seen on the figure below.

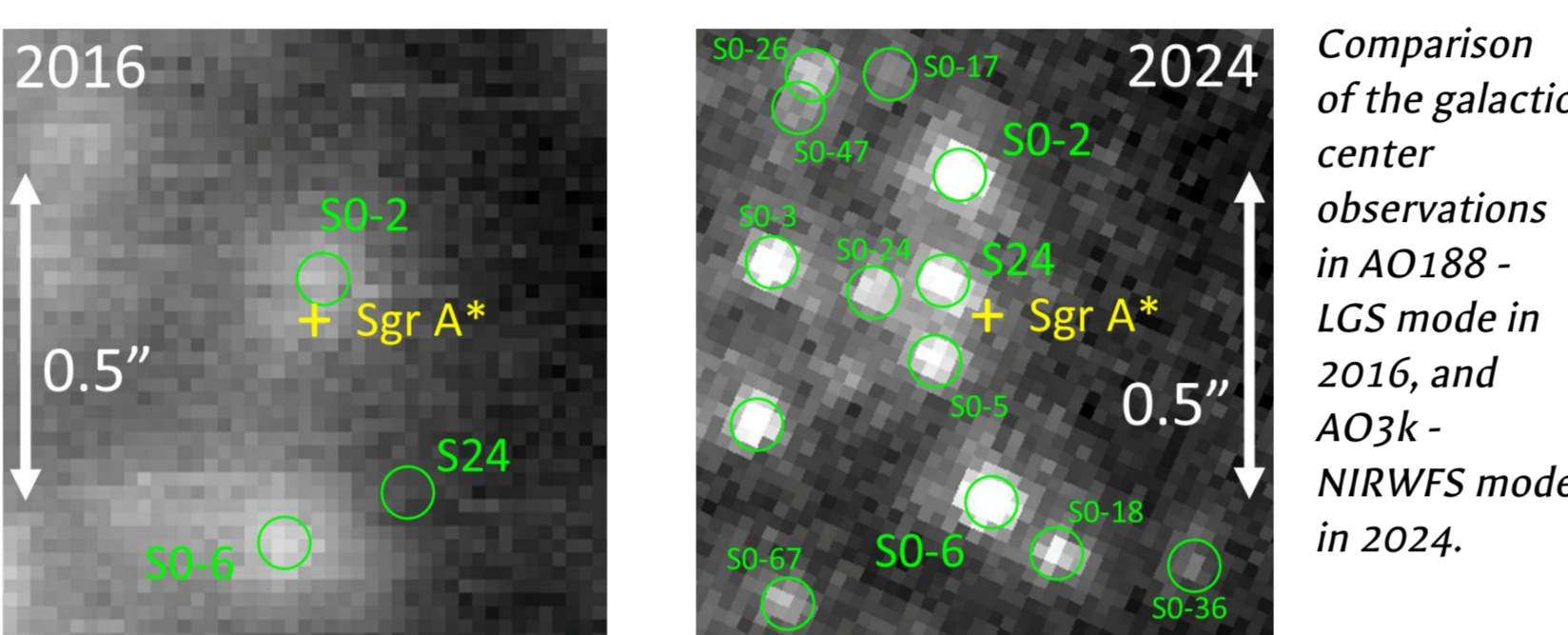

The NIR WFS has different dichroics that can be used to split the light between wavefront sensor and science, each dichroic has a range of magnitude limits that can be accessed, depending on the speed of the camera, the filter used, but also the spectrum of the guide star. Red stars have lower H-band magnitude limits than A-type stars for example. A new lo-res (LR) mode, optically reducing the pupil sizes by a factor 2, increase the magnitude limits of the original hi-res (HR) mode by 1.5 mag.

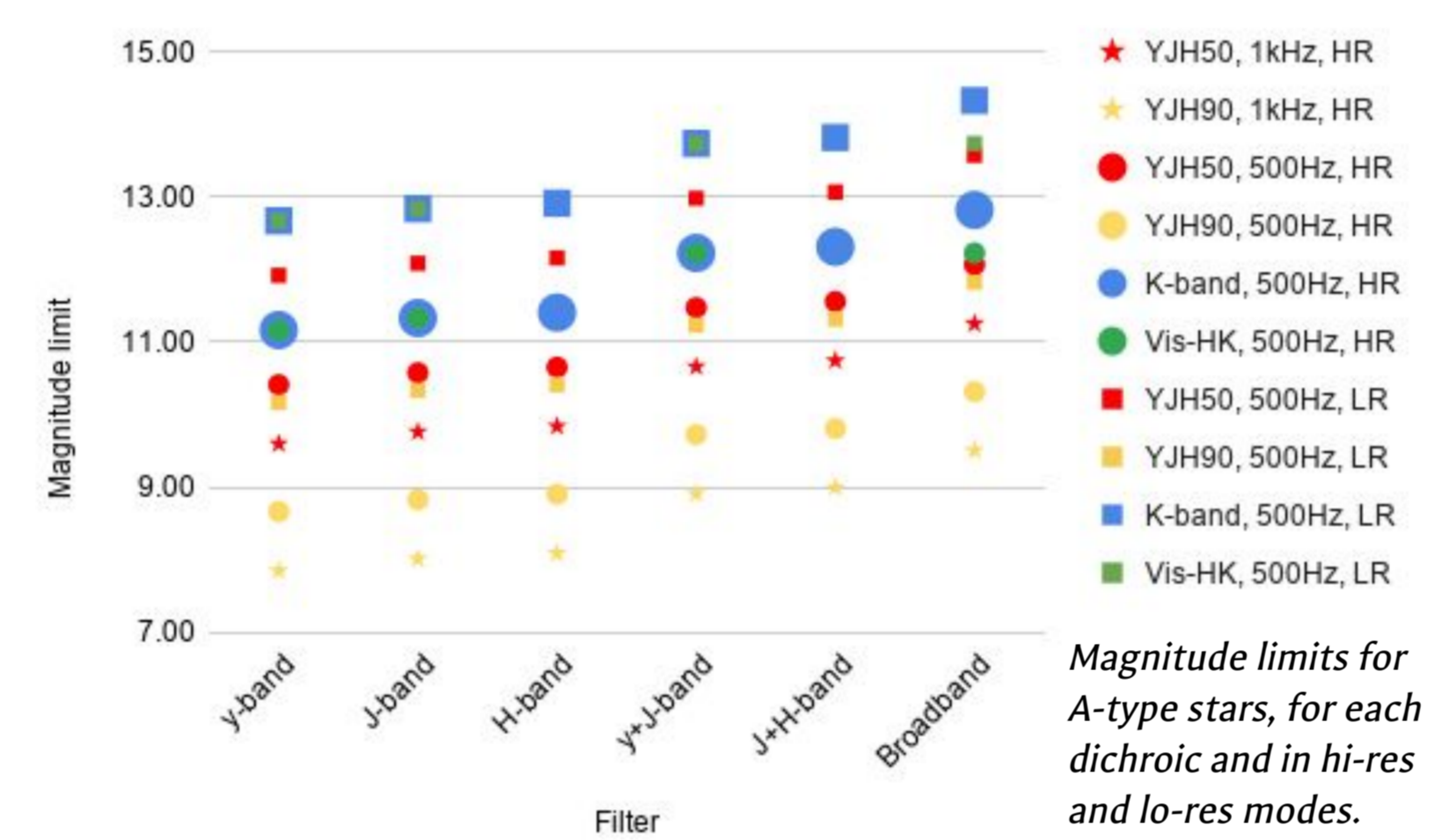

Magnitude limits for A-type stars, for each dichroic and in hi-res and lo-res modes.

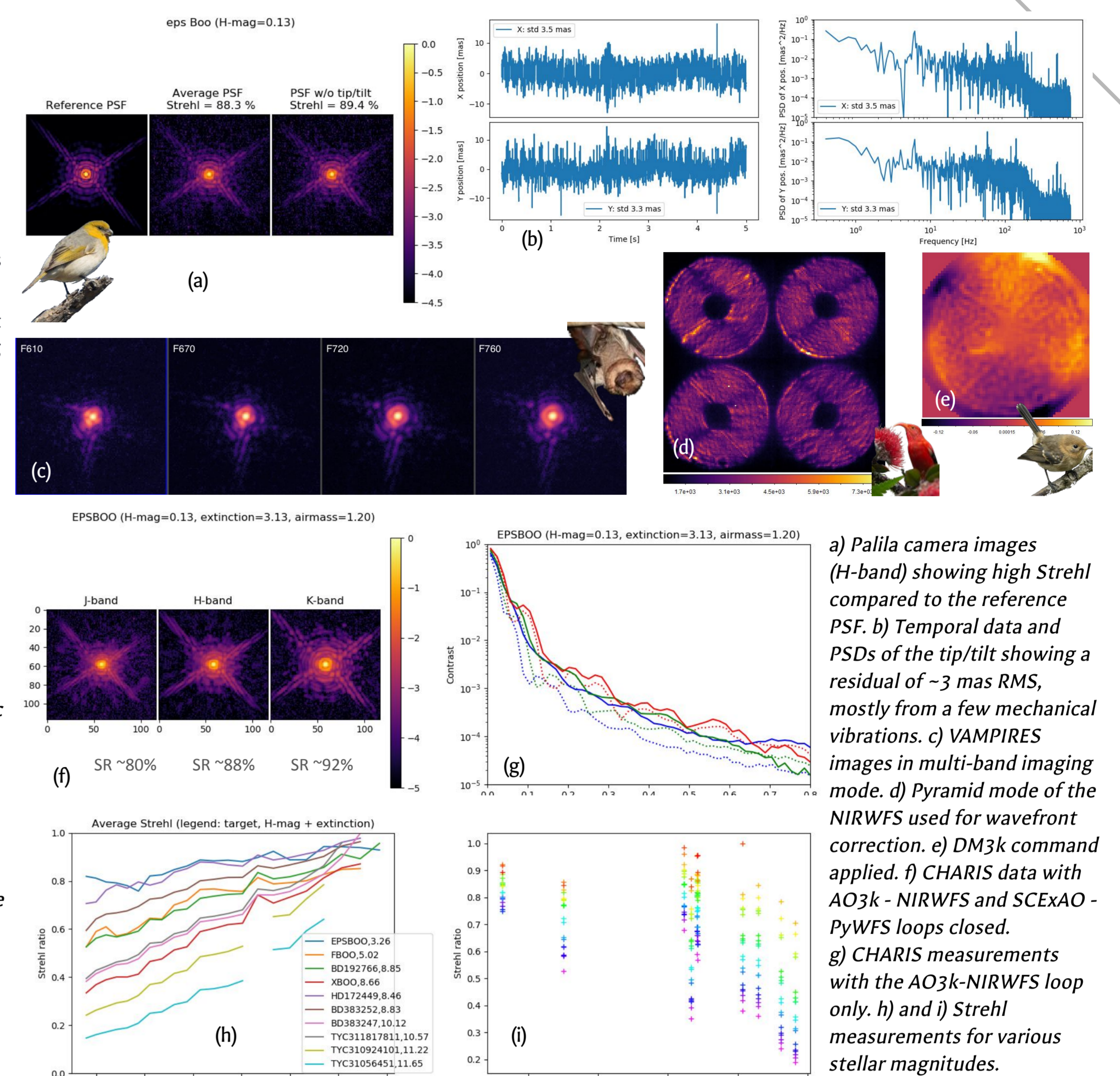

Phase II of the AO3k / NasIR upgrade just happened summer 2025, with the addition of the Nasmyth Beam Switcher and the LTAO (ULTIMATE-START). In this phase, the NIRWFS was upgraded and moved to the LTAO platform. The upgrade includes several additions:

- A dichroic pickoff wheel, with all the available pickoffs for an easy and automatic switch depending on the target. A L-band dichroic was added in the new wheel.
- A field stop, to block stray light from other stars, especially for binaries and crowded fields. This should improve the correction in these cases.
- An optical binning mode, where the pupils for the PyWFS modes are reduced by a factor 2, allowing to reach fainter targets, although with less corrected modes (lo-res mode).
- An infrared acquisition camera, which should improve the overhead for target acquisition, especially for optically faint guide stars.

NIRWFS v2 performs as well as v1, now with more functionalities and better magnitude limits thanks to the LR mode. Work is in progress to implement the acquisition camera and test the L-band dichroic.

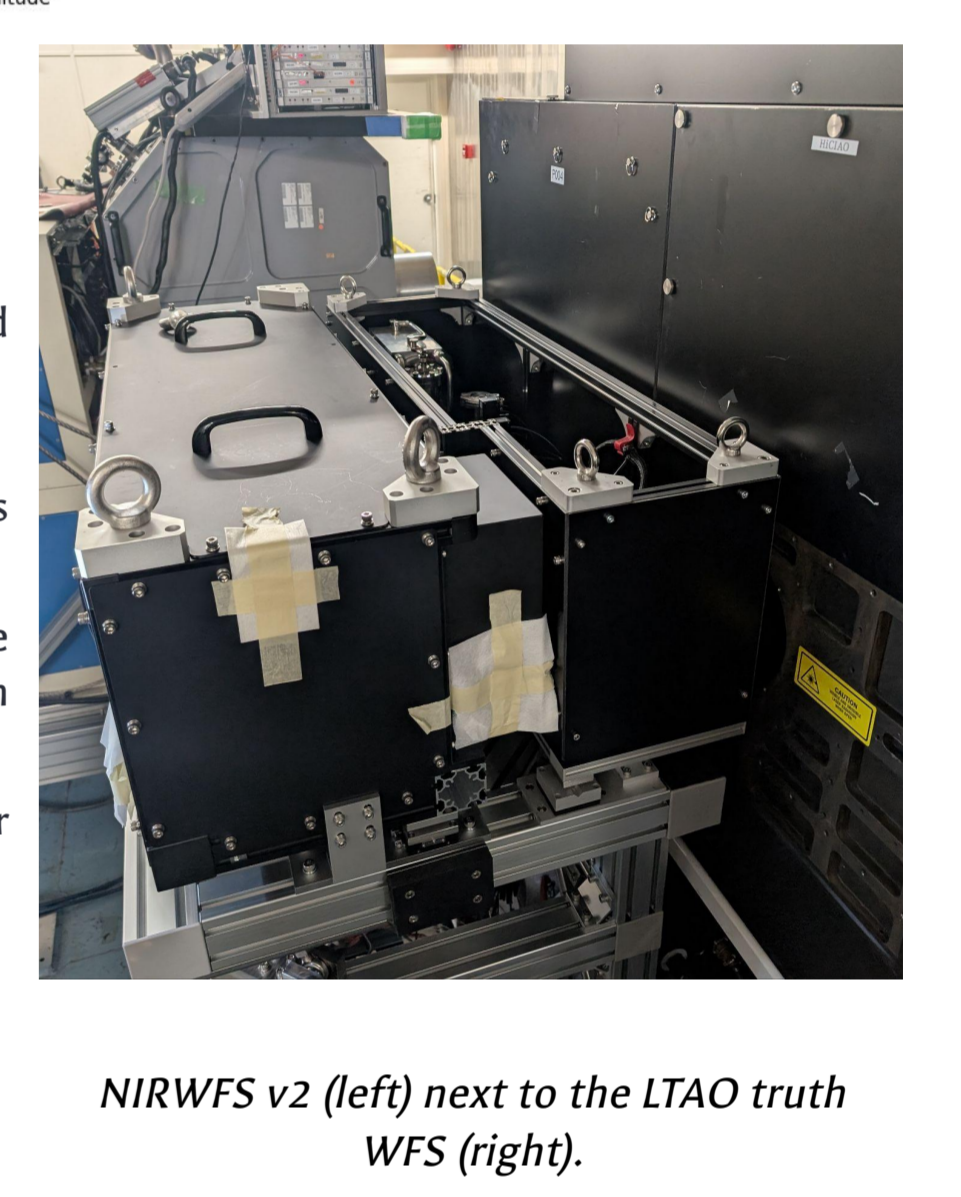

NIRWFS v2 (left) next to the LTAO truth WFS (right).

III. AO3k - nCWFS

The non-linear curvature wavefront sensor (nCWFS) is planned to replace the current visible WFS for the AO3k system, which is the upgraded version of the AO188.

We successfully finished the AO performance evaluations in the lab and commissioned the nCWFS inside of the AO188 box in November 2023.



Left: 3D CAD model of the nCWFS (top) and actual implementation inserted in AO188, just over the current visible WFS (bottom).

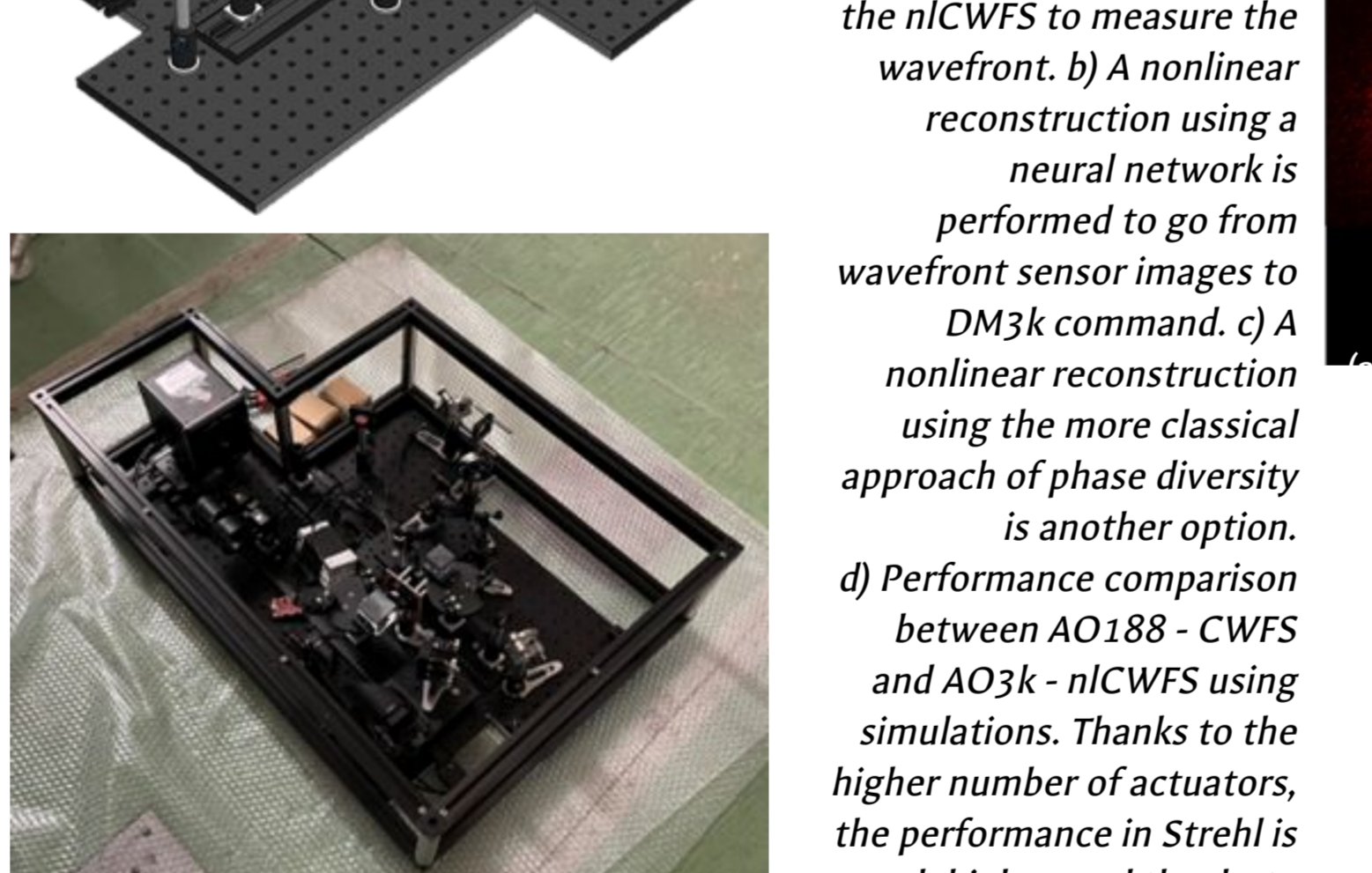

Right: a) Four defocused pupil images are used by the nCWFS to measure the wavefront. b) A nonlinear reconstruction using a neural network is performed to go from wavefront sensor images to DM3k command. c) A nonlinear reconstruction using the more classical approach of phase diversity is another option. d) Performance comparison between AO188 - CWFS and AO3k - nCWFS using simulations. Thanks to the higher number of actuators, the performance in Strehl is much higher, and thanks to a low sampling mode, we should be able to reach fainter magnitudes.

- On-sky results:**
- To close the AO loop, we first took an on-sky response matrix (RM) while the NIRWFS loop was closed.
 - Even with on-sky RM measurement, we could get clear responses of the control modes at the deformable mirror (DM) thanks to the NIRWFS loop. (see figures below).
 - After taking the on-sky RM, we tried to close the AO loop with the nCWFS.
 - Close loop was attempted for the first time in August 2024. Target: Alpha Cet, Seeing: 0.8" ~ 1" (see figures on the right).
 - We confirmed the closed-loop AO3k performance with the nCWFS.
 - The highest Strehl ratio was 35% at 0.8" seeing condition.
 - We anticipate the nCWFS will provide a full AO3k capability with the new 3k DM after optimizing the closed-loop performance.

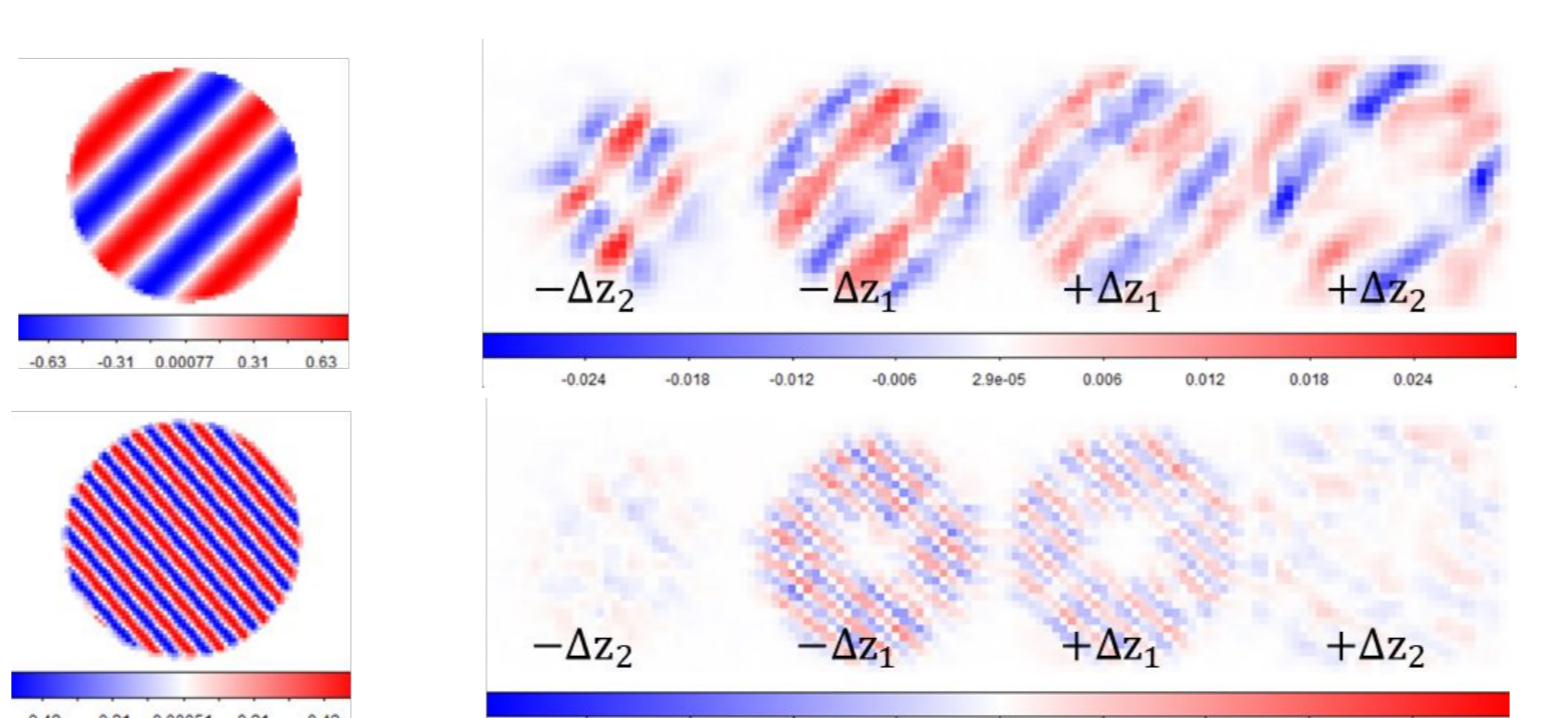

Left: Injected phase on the DM3k. Right: Response of the nCWFS.

The current visible curvature WFS uses two defocused pupil images for WFSing. However, the nCWFS utilizes four defocused pupil images to have a decent sensitivity for both low-order and high-order aberrations.

Two near-pupil images are for high-order aberrations, and two far-pupil images are for low-order aberrations. We also plan to deploy non-linear wavefront reconstruction methods for an extensive dynamic range.

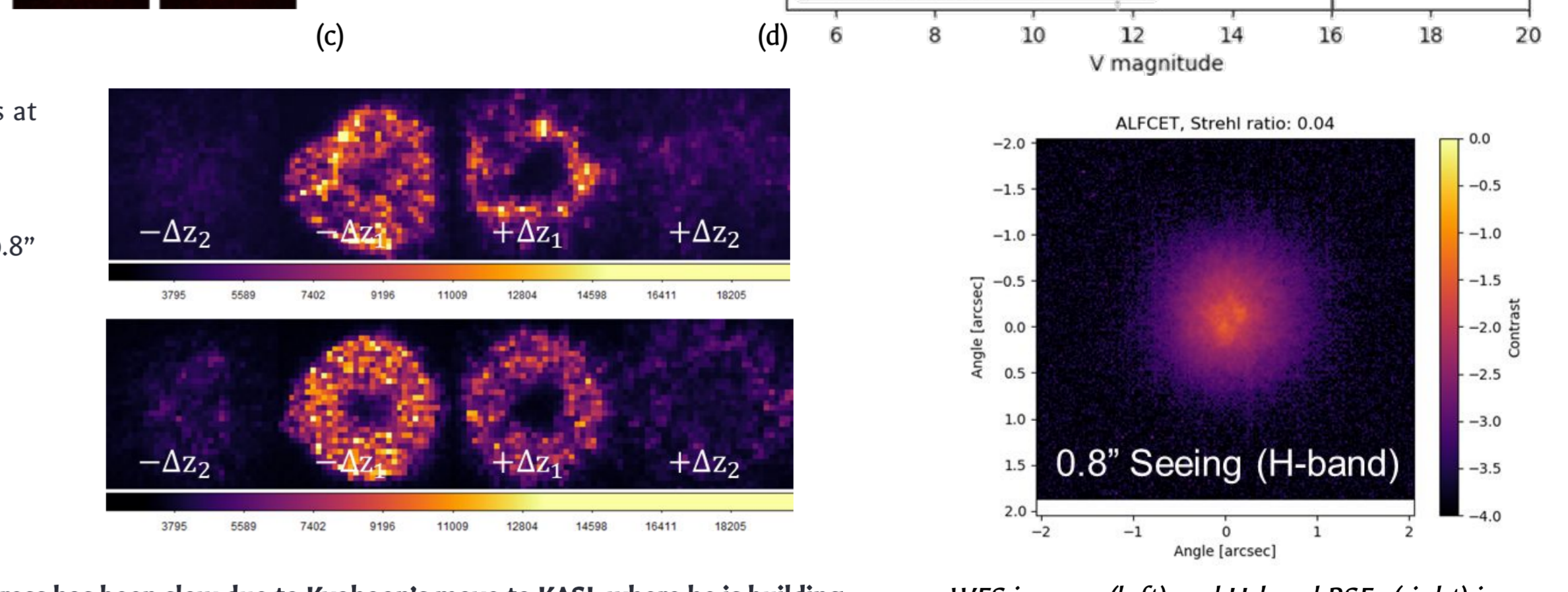
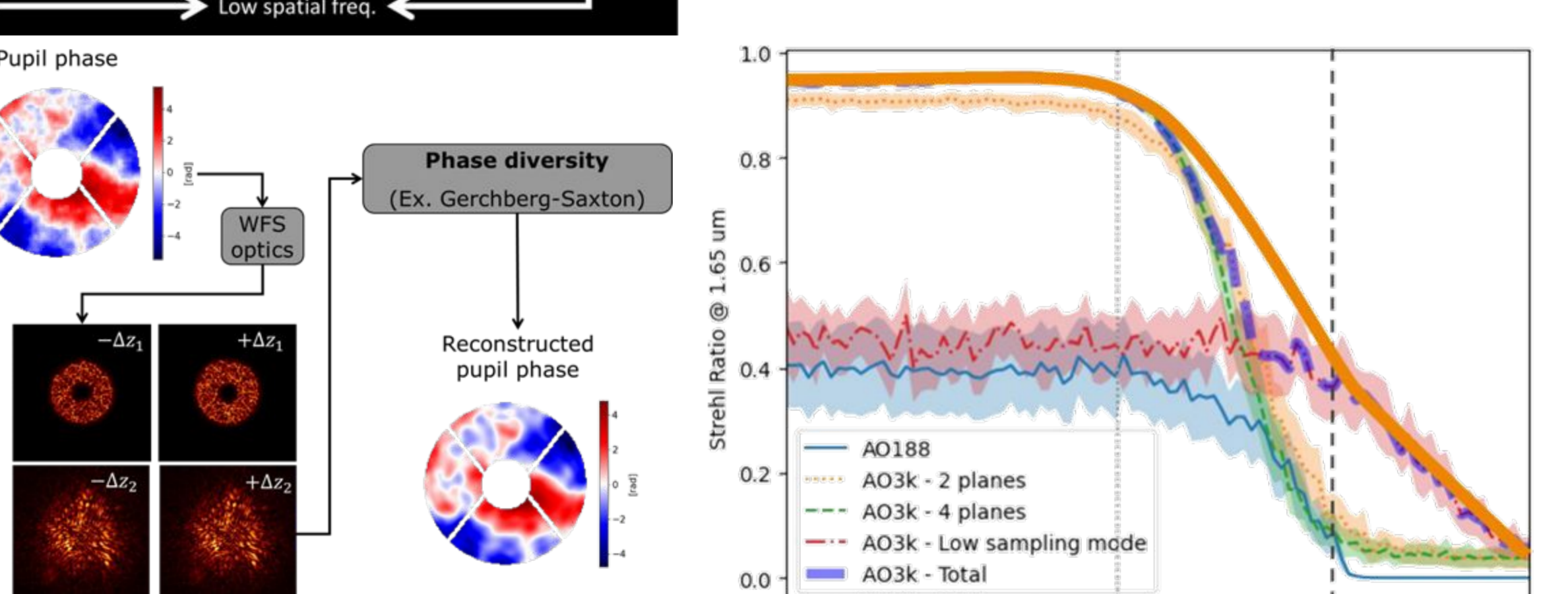
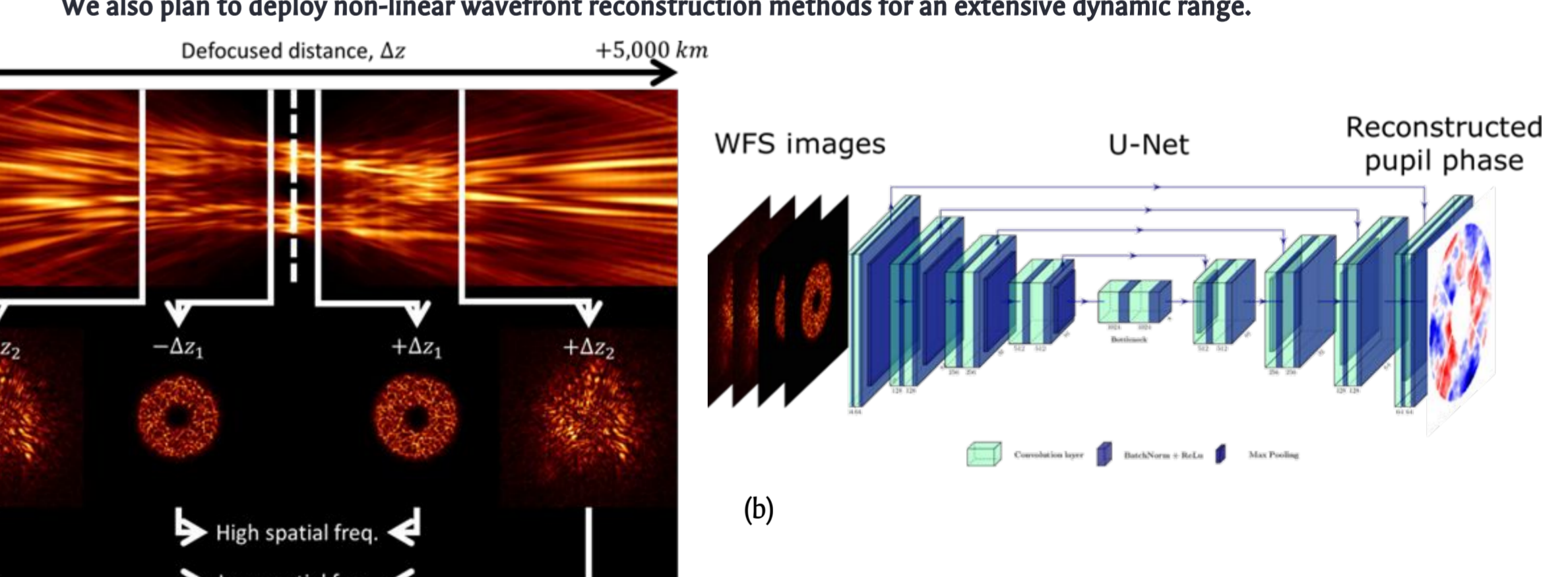

WFS images (left) and H-band PSFs (right) in open (top) and closed loop (bottom)

- Progress has been slow due to Kyohoon's move to KASI, where he is building a second testbed locally. The nCWFS was removed from AO188 in May 2026 to debug the AU1 motor issue, and will be reinstalled in August 2026. Then, we will:
- Optimize AO performance for various conditions.
 - Compare quantitatively the AO performance between the current visible WFS and the nCWFS.
 - Upgrade the mechanical design to provide different modes: NGS, LGS and focal plane WFS.
 - Deploy the non-linear wavefront reconstruction algorithms.
 - Open the nCWFS to the community as a PI-type module.