

Technology verification for WFOS IFU

Shinobu Ozaki, Yoko Tanaka, Takashi Hattori (NAOJ),
Tsuyoshi Ishigaki, Aika Kabe (Iwate University)

We are aiming to develop an IFU for Wide Field Optical Spectrograph (WFOS), one of the first-generation instruments of TMT, and now conducting some R&Ds on basic technologies for developing the IFU. To verify the technologies, we will develop an IFU (Tech. IFU) installed in FOCAS. In this presentation, we introduce Tech. IFU and its progress.

WFOS IFU

WFOS IFU is not a baseline of WFOS so far. However, In the review in last August, the reviewers recommended to include the IFU as part of the WFOS baseline design.

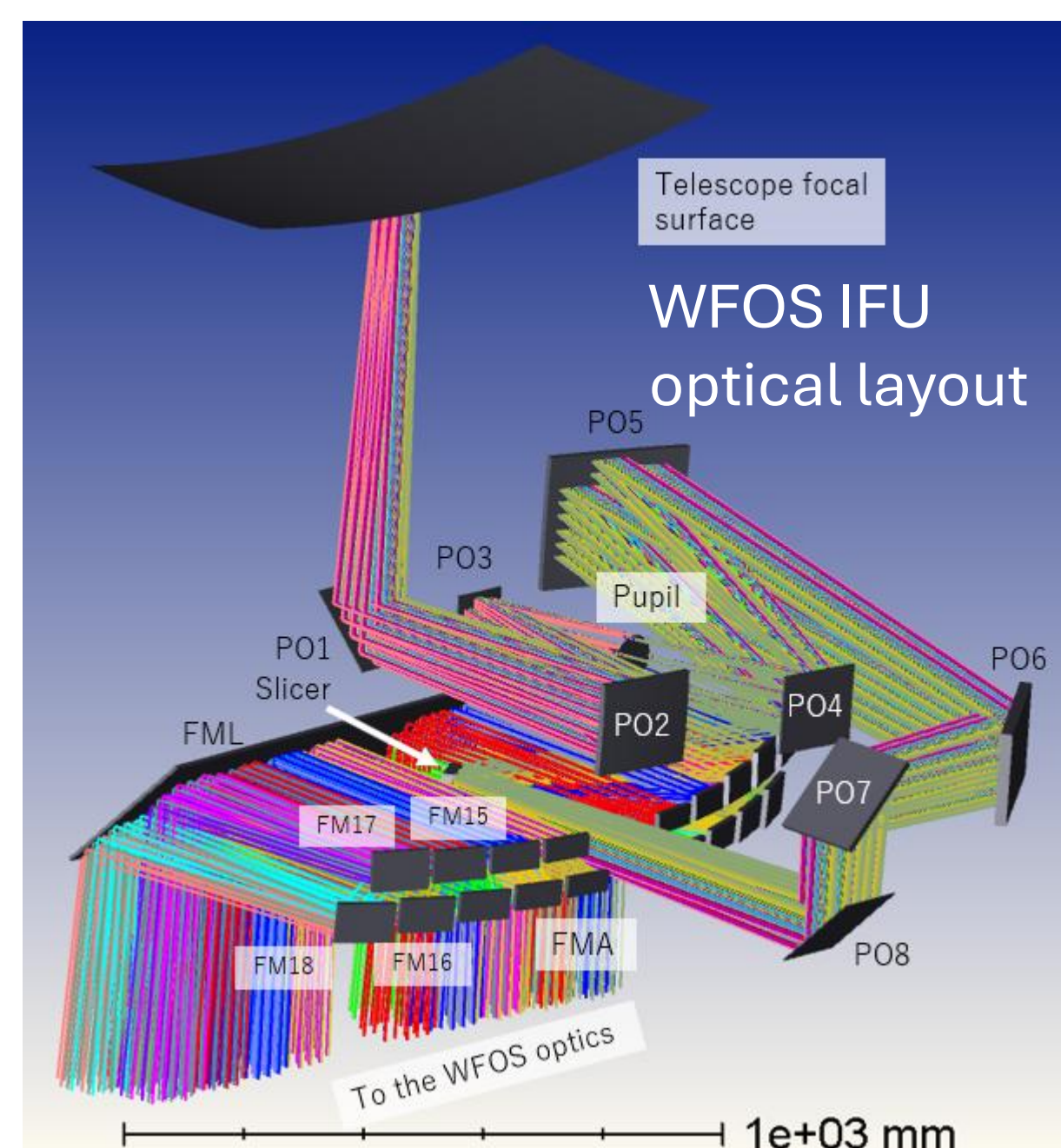
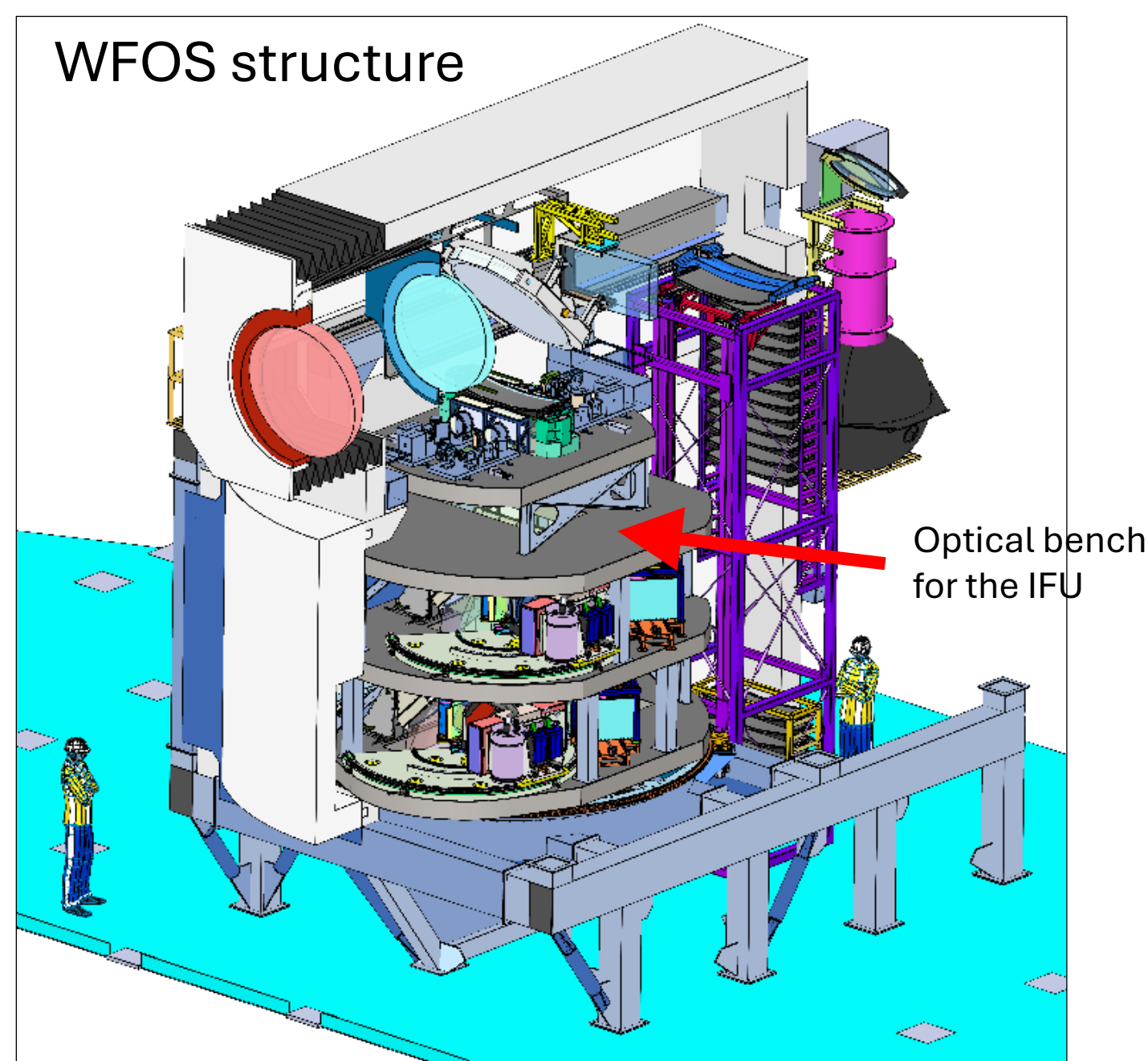

Number of slices	18			
Slice length (arcsec)	20			
Slice width (arcsec)	1.5	0.75	0.5	0.25
FoV (arcsec x arcsec)	20 x 27	20 x 13.5	20 x 9	20 x 4.5
Spectral resolution (R) for each grating in the IFU mode				
R=1500 grating	682	1364	2046	4092
R=3500 grating	1591	3182	4773	9546
R=5000 grating (goal)	2273	4545	6819	13635

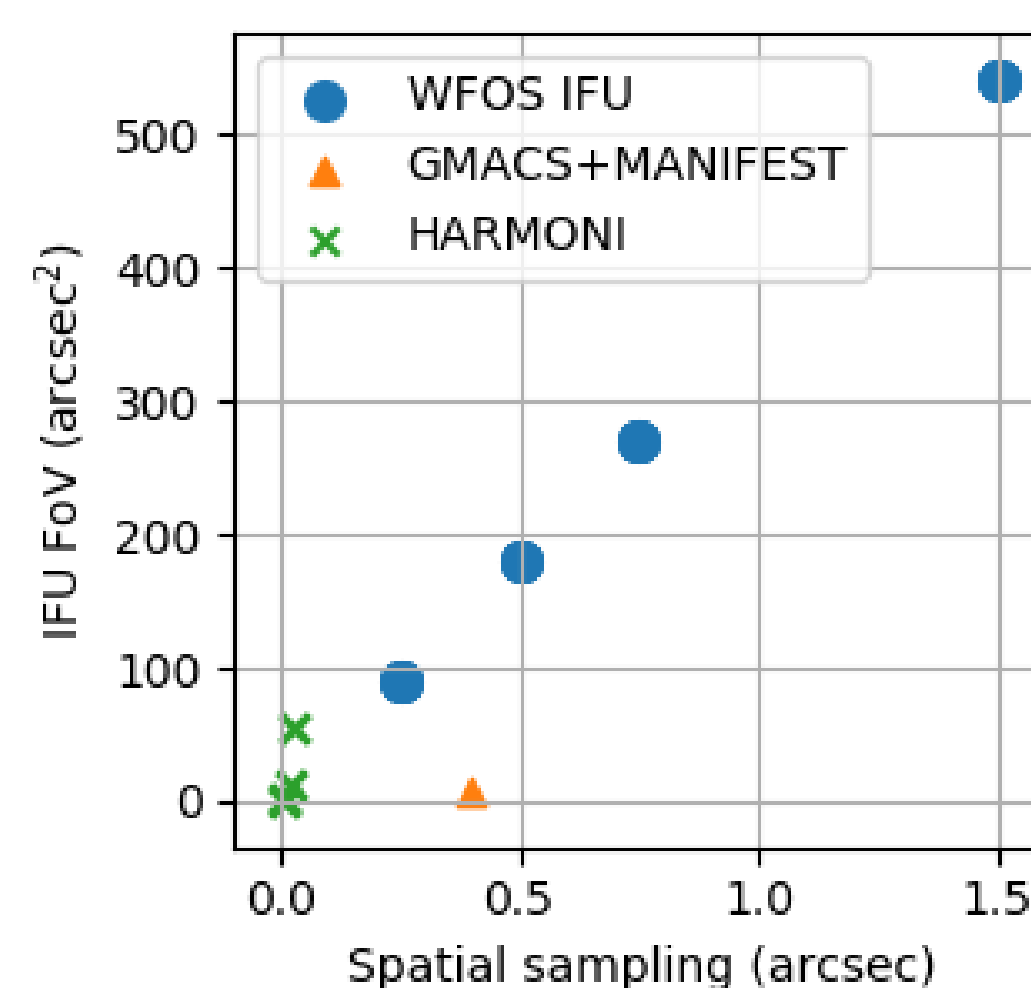

WFOS IFU has 4 slicers which have different slice widths. The wider width modes have outstandingly wider field comparing other IFUs on extremely large telescopes. In the narrowest width mode, the spectral resolution reaches R=13,635 without slit loss.

Project overview of Tech. IFU

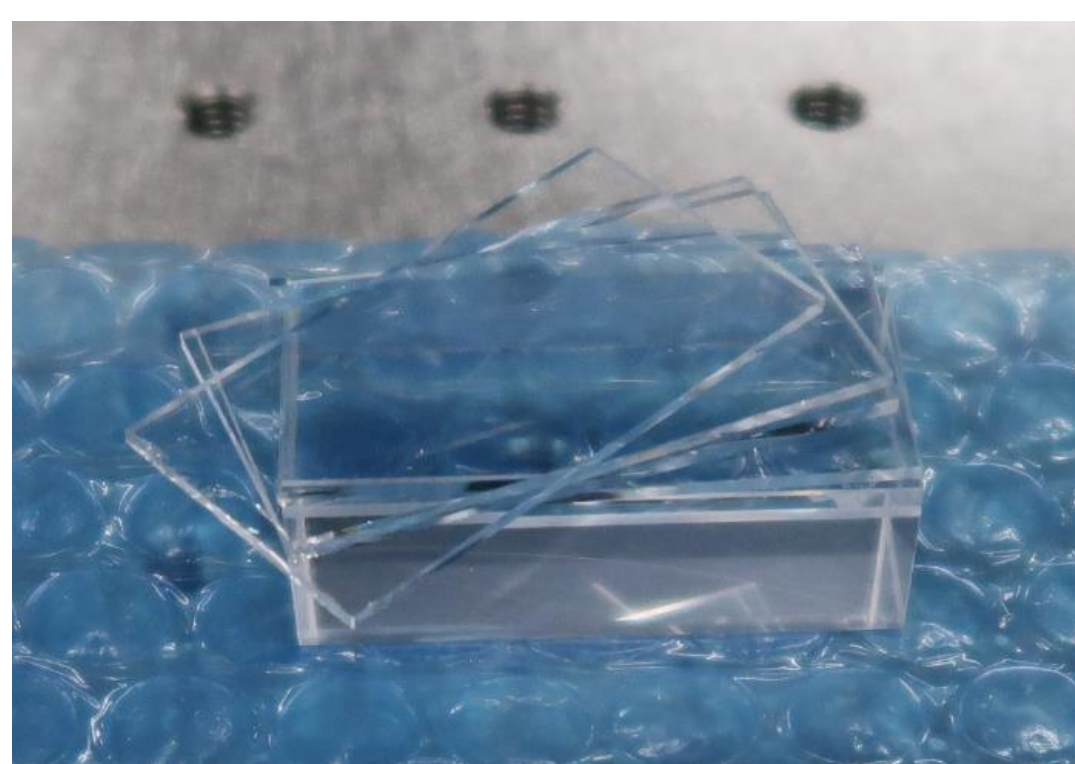

We are now conducting some R&Ds toward WFOS IFU. Tech. IFU is a testbed for verifying the technologies obtained from the R&Ds and is installed in the optical imaging spectrograph, FOCAS, on the Subaru telescope.

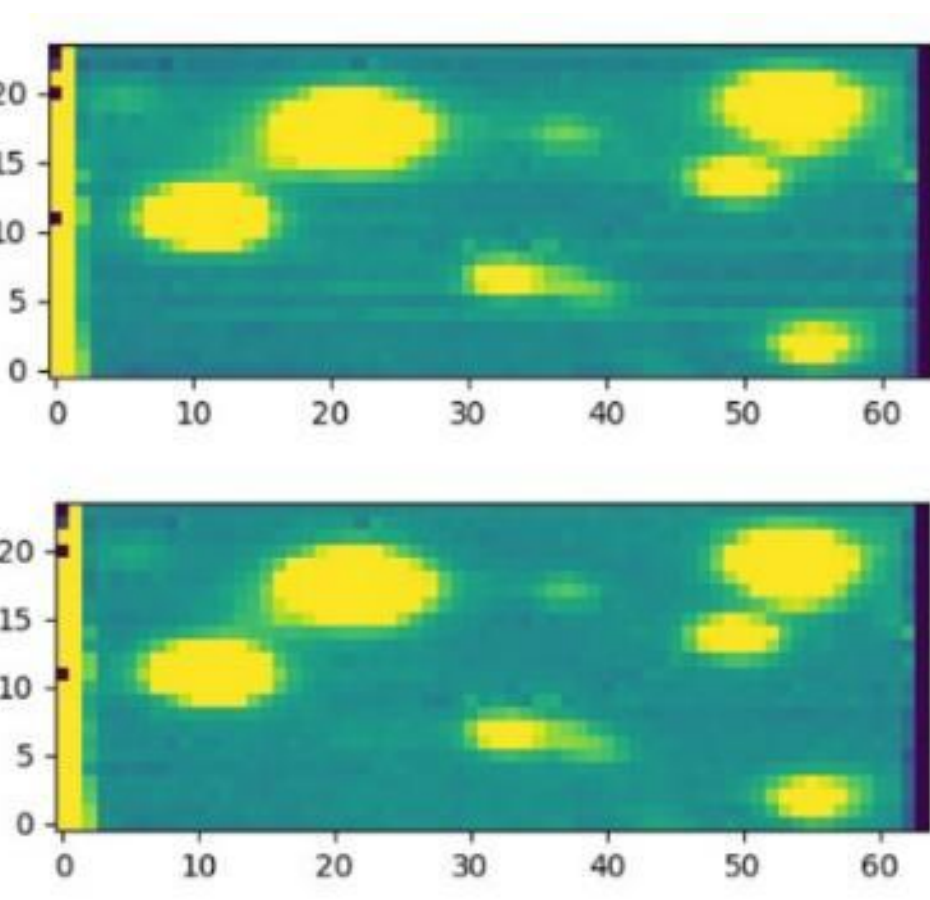
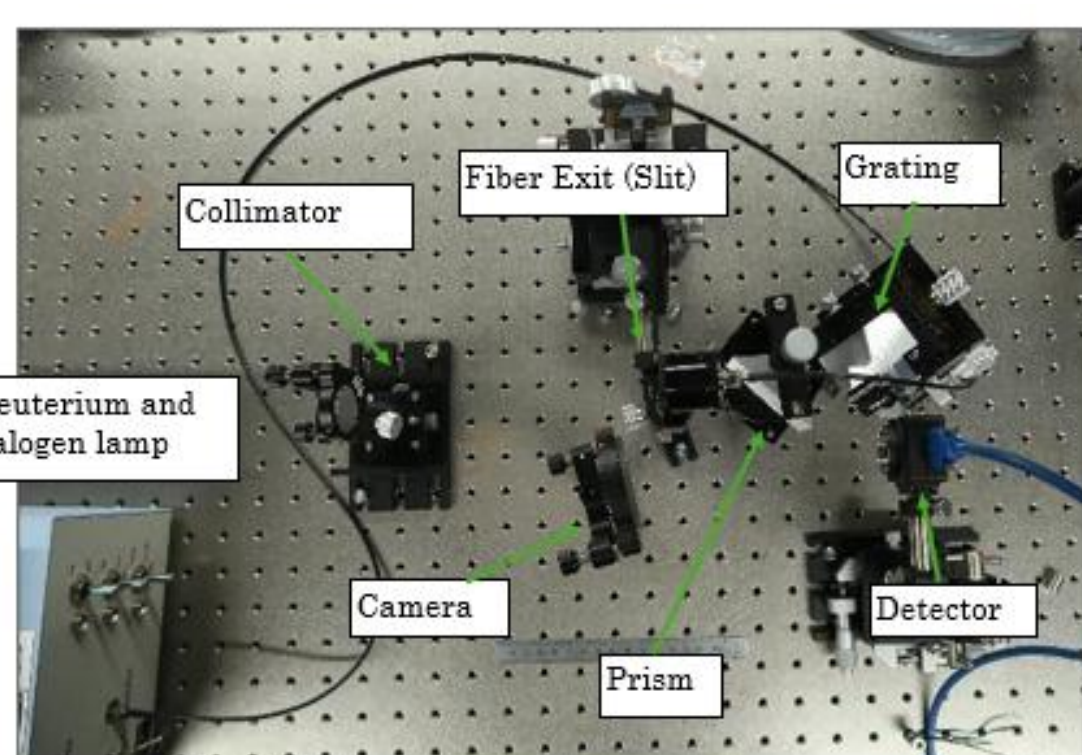
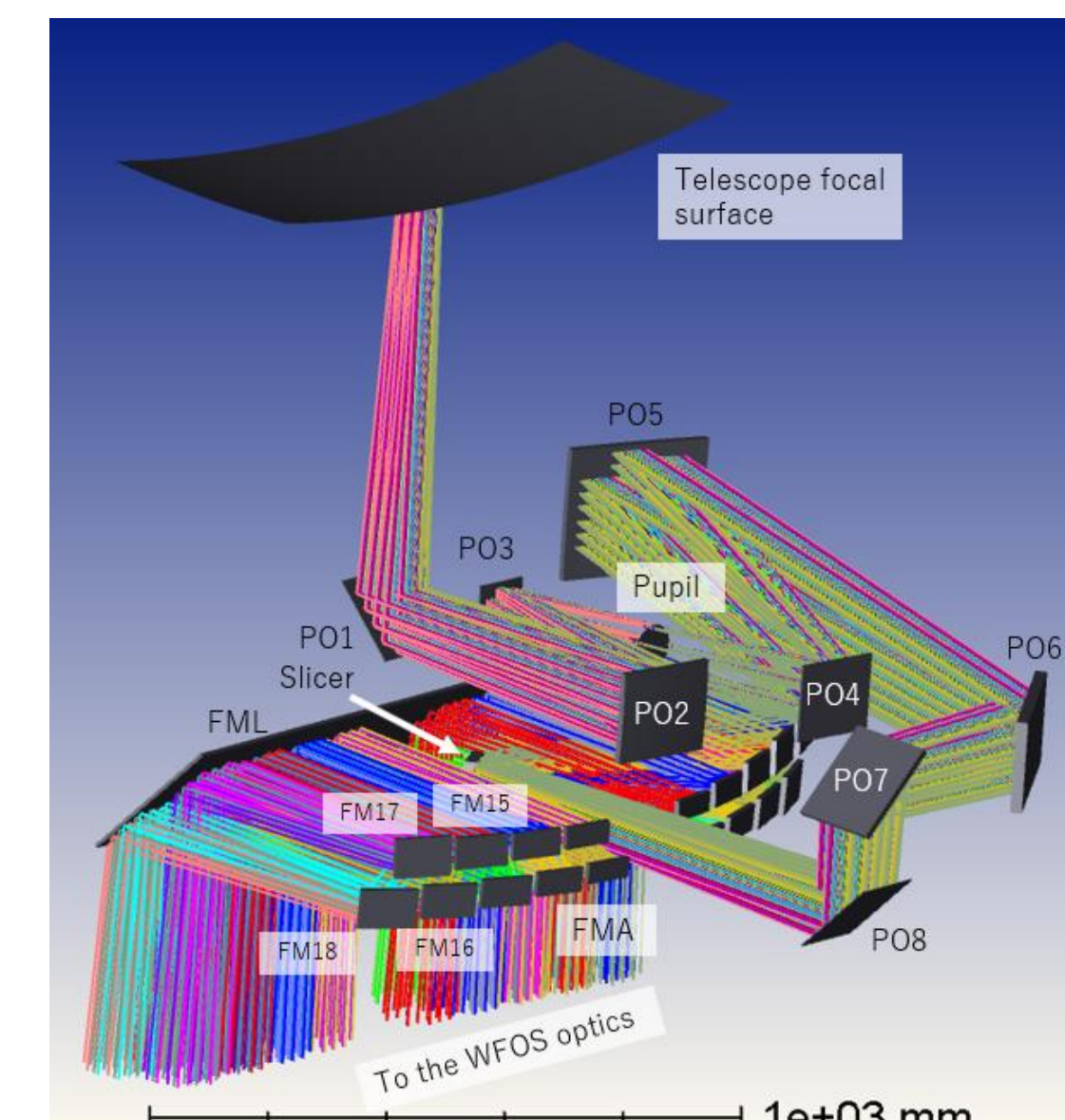
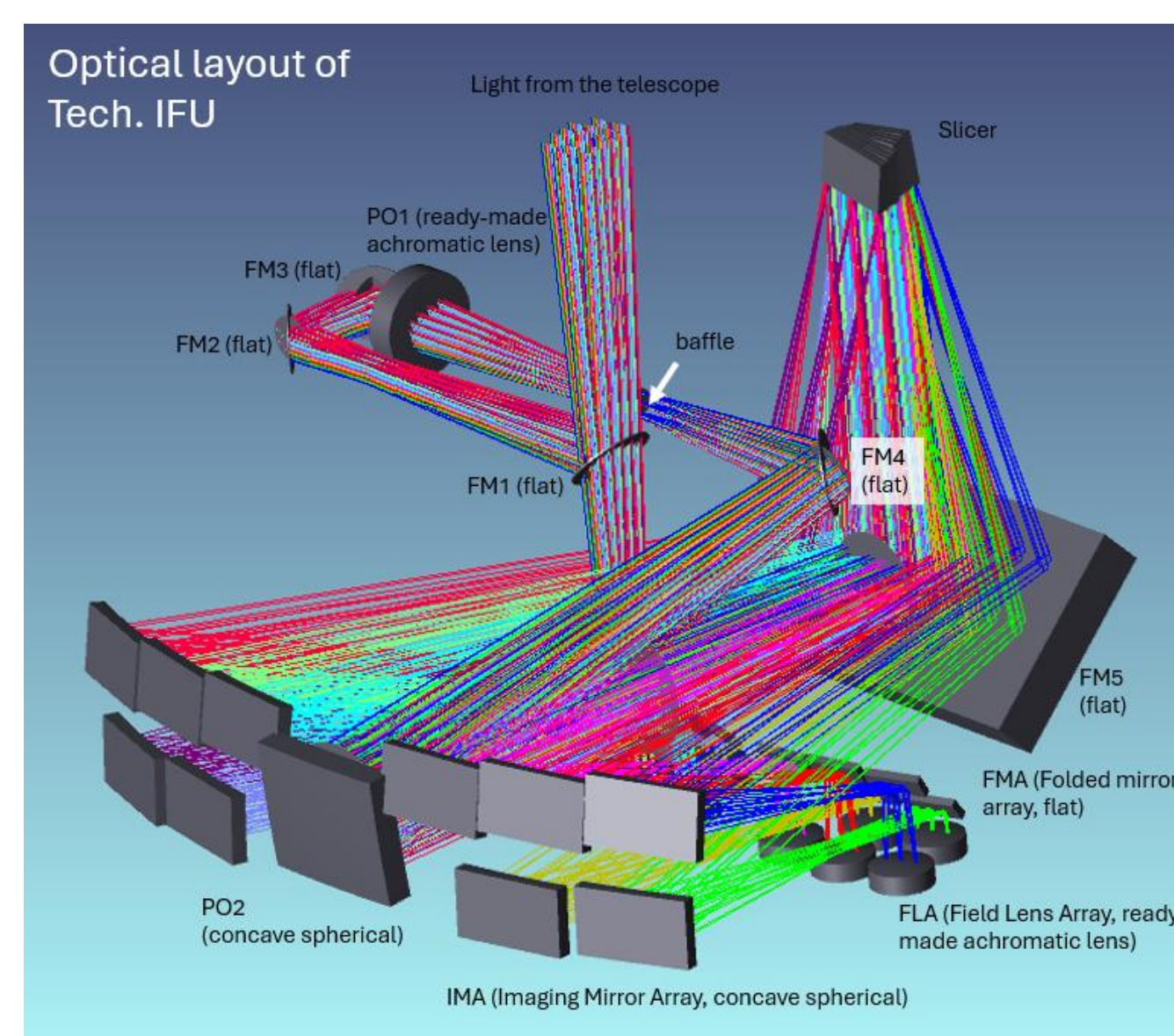
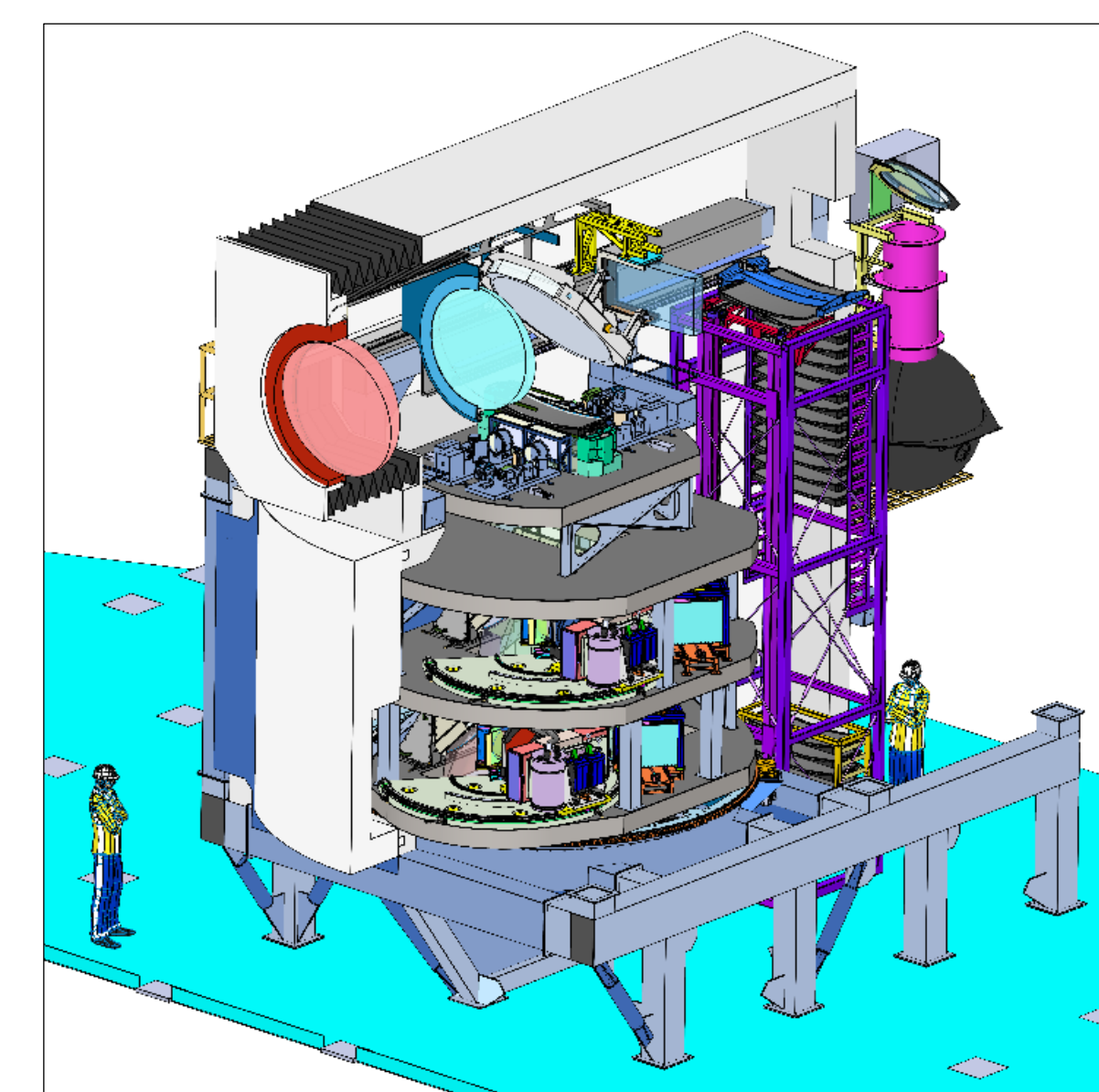
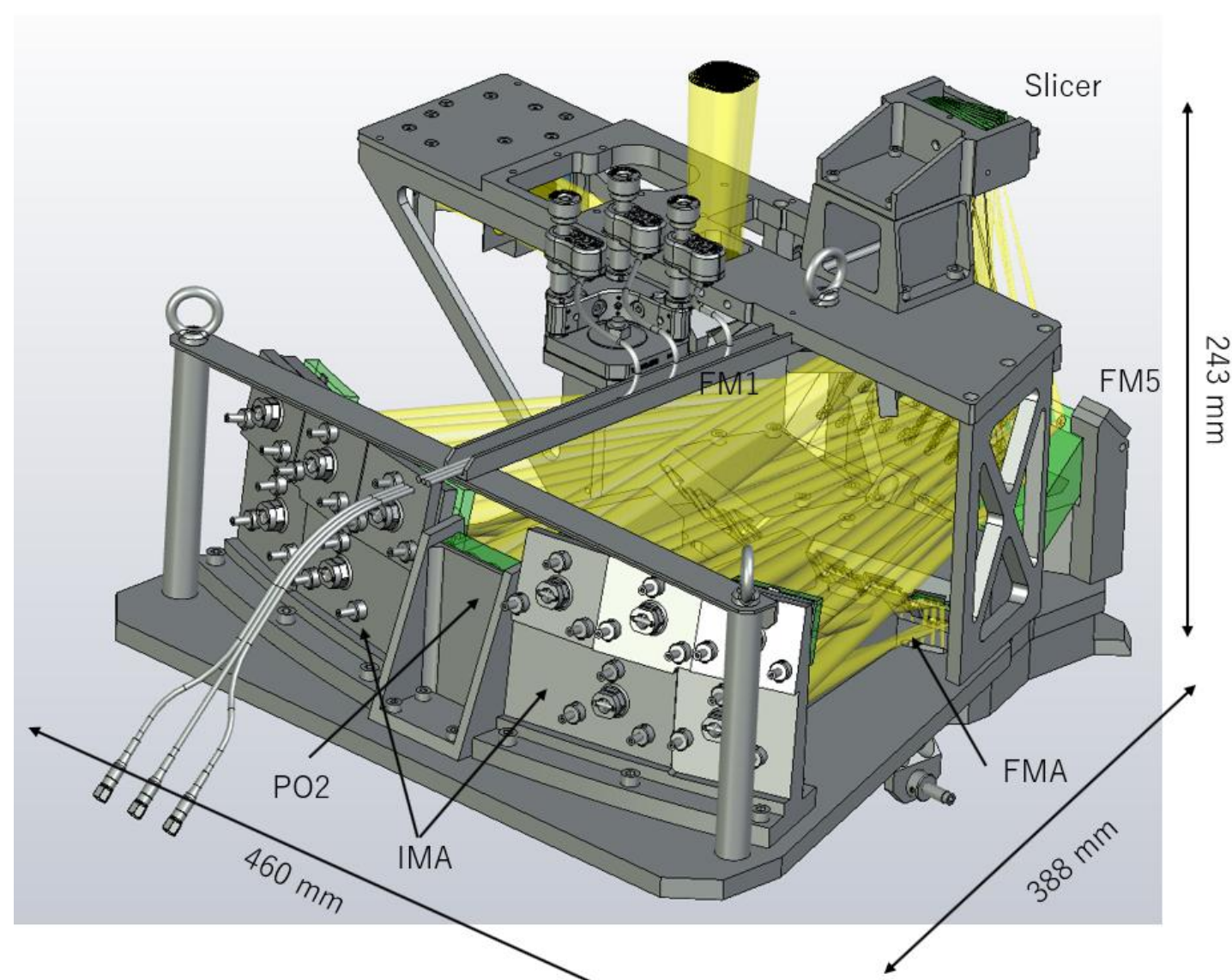
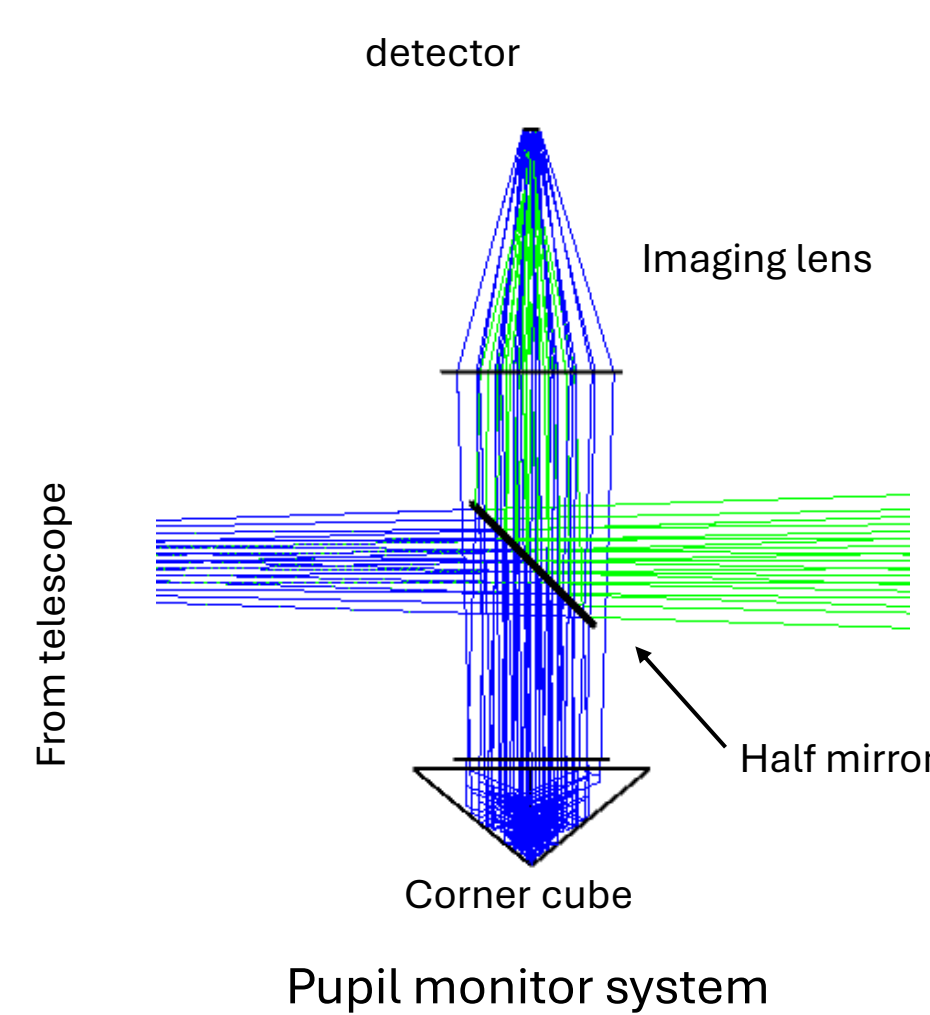
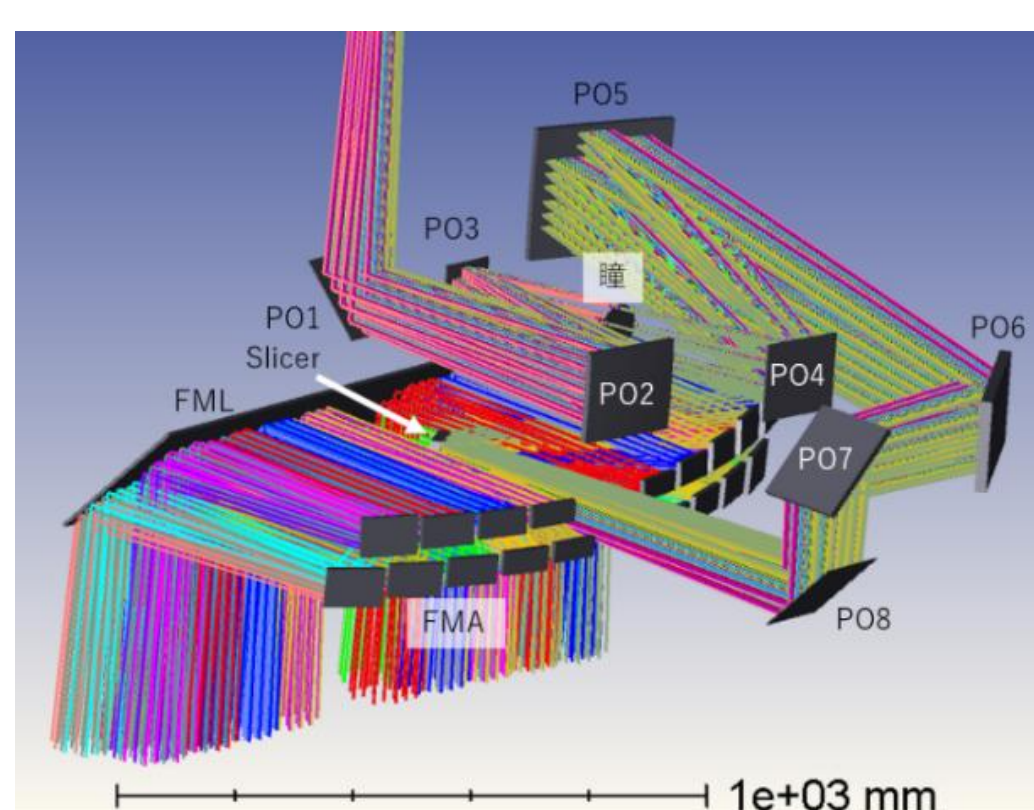

Tech. IFU

WFOS IFU

Progress since the last UM and future

Assembly test of an image slicer

An image slicer has a complex structure and requires high alignment accuracy of slice mirrors. Establishing its manufacturing method is the most important technical issue.

Assembling is one of major processes of the manufacture. So far, we have developed an assembling jig and tested the assembly process. Since the last UM, we improved the jig and conducted an assembly test. And it is confirmed that the alignment accuracy meet our requirement (< 0.03 degree) with some margin.

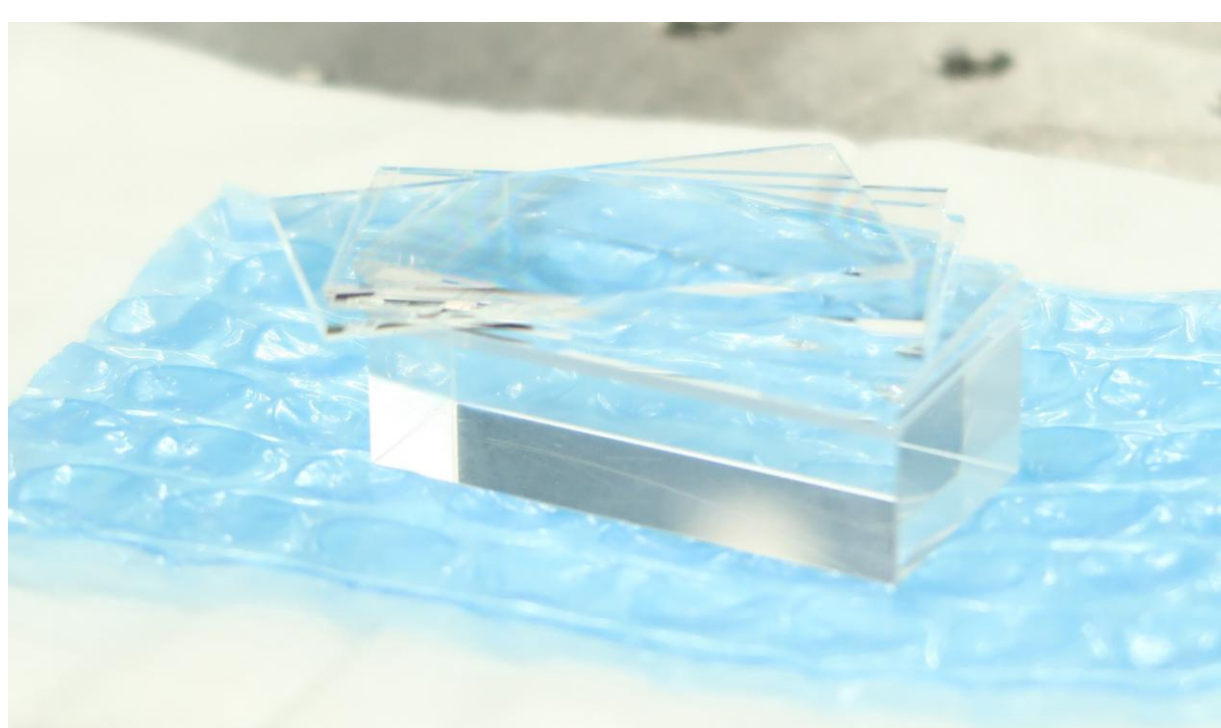

Future works

We confirmed feasibilities of each manufacturing processes of an image slicer. We will conduct a prototype of an image slicer with an end-to-end manufacturing processes obtained from R&Ds so far.

We will also complete detailed designing of the Tech. IFU in this fiscal year.