

# Subaru GLAO Simulation

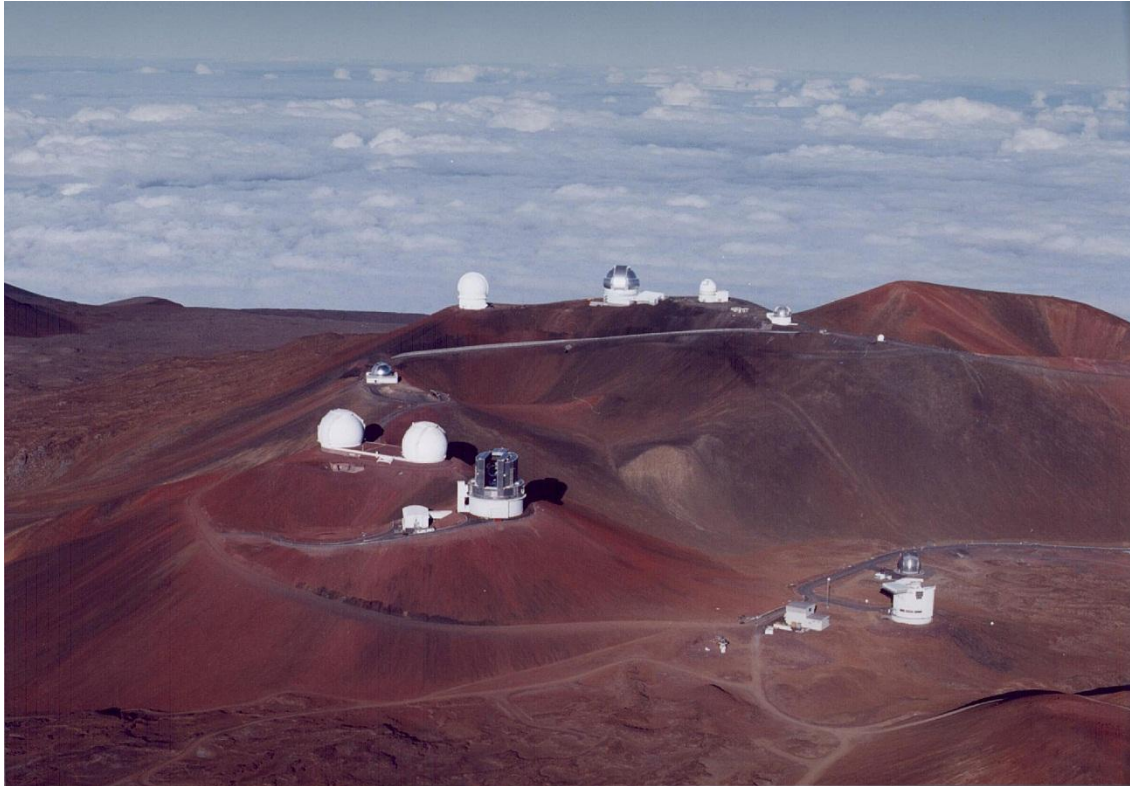

Shin Oya (Subaru Telescope)

2012/6/4 @ Hilo

# Background

## Subaru Telescope

- LGSAO188: commissioning is finishing
- optical instruments (dark nights)
  - huge projects for prime focus
    - HSC: Hyper Suprime Cam **on-going**
    - PFS: Prime Focus Spectrograph **partial budget approved**
- next Cs Infrared instruments (bright nights) w/ **AO**
  - **discussed by internal committee**

## TMT

- contribution to the development: not only the telescope, but also the instruments incl. **AO**

# Current View

- Wide field AO is suitable for Subaru future plan
  - synergy with seeing-limited wide-field instruments
  - competitiveness among 8m-class telescopes
  - complementarity with 30m-class telescopes
- GLAO by deformable 2ndry is 1<sup>st</sup> candidate
  - 10-15 arcmin FoV; 1 mag gain; 1000act ASM
  - deformable 2ndry: on-source high order / low emissivity
  - MOIRCS like wide-field IR instrument at Cassegrain
- Study is needed
  - technical feasibility, time-line, budget plan, etc. (Hayano-san)
  - performance simulation / seeing data (Oya)
  - science case, instrument (Iwata-san)

# Outline of my part

- What is Ground Layer Adaptive Optics (GLAO)?
  - a type of wide-field AO
  - Mauna Kea seeing (which determines GLAO performance)
- Simulation to evaluate performance
  - Code, seeing model, configuration
  - Correction
    - wavefront error (WFE)
    - profile (FWHM & ensquared energy; wavelength dependency)
  - Field-of-View
    - mechanical limit: Cs  $8.6' \phi \Rightarrow 20' \phi$  w/o ADC (cf. Ns  $4' \phi$ )
    - constraint from performance?
- Adaptive Secondary Mirror (ASM) applications

# AO types

finer correction

(increasing the number of elements)



Correction  
Performance

HiCIAO/SCEXAO

Wide field AO  
(Subaru ngAO)

High Contrast  
High Strehl

ExAO  
extremely  
high-order

LTAO  
laser tomography  
with IR-WFS

RAVEN

Diffraction Limited

Conventional  
AO  
single DM and WFS  
LGSAO188

MCAO  
multi DM  
and WFS

MOAO  
AO unit for  
each target

GLAO  
ground-layer  
correction only

Seeing Improvement

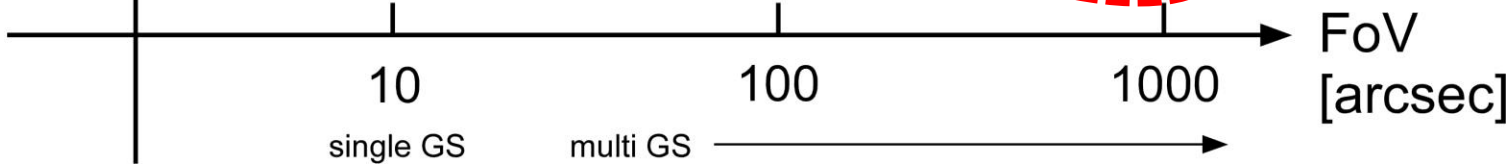

more layer correction  
(increasing the number of DM & WFS)

# What is GLAO?

Wide-field AO (incl. GLAO) needs

Tomography

- Considering 3D structure of atmospheric turbulence
- Multiple guide stars

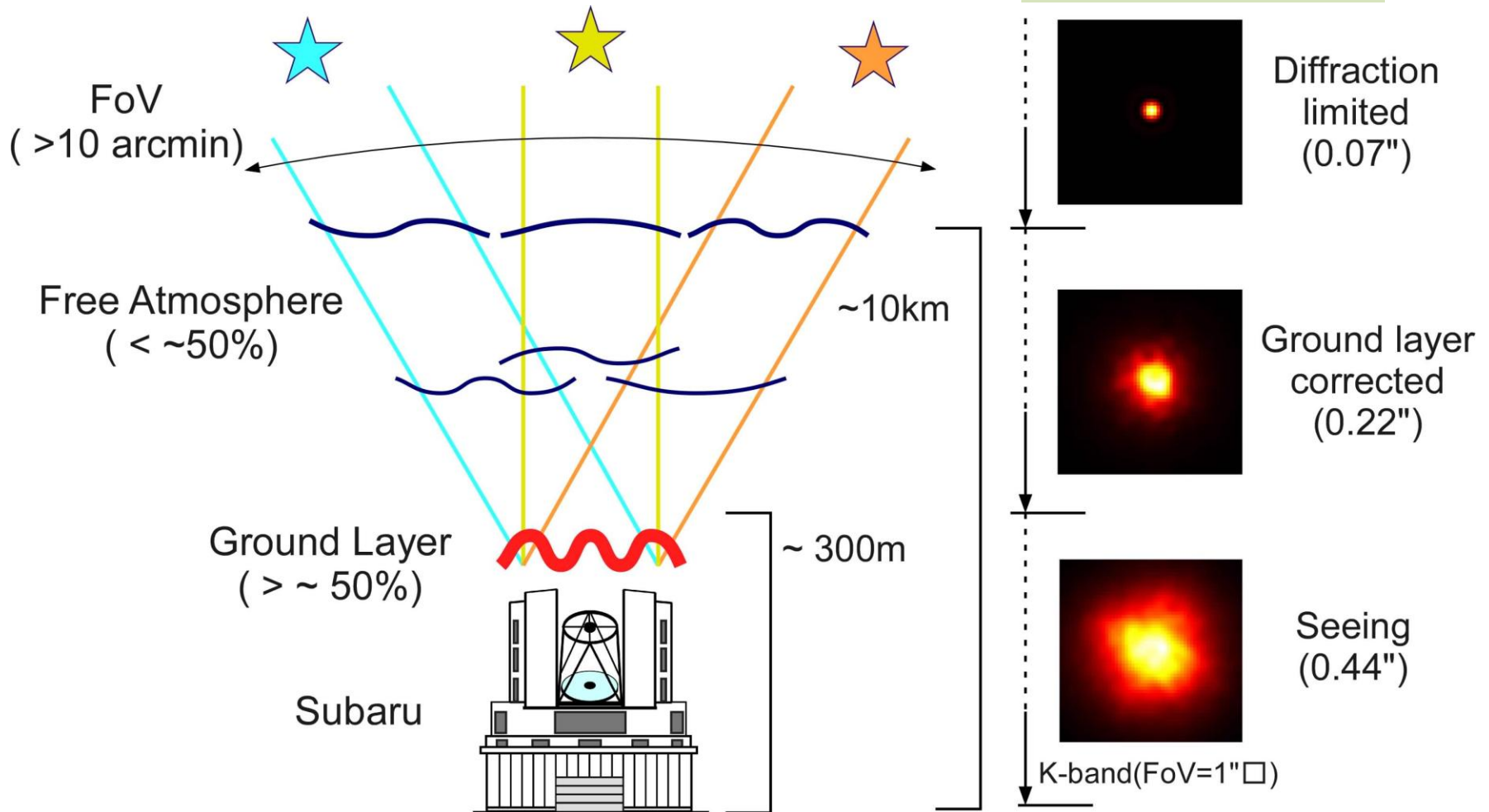

# Mauna Kea Seeing: ground layer

– Concentrated close to the surface

suitable for  
GLAO

- Summit ridge (~70 m above Subaru)  
Chun+09, MNRAS, 394, 1121
- SLODAR (~2yr)
- LORAS (~1yr)

- TMT site (~90m below Subaru)  
Els+09, PASP, 121, 527
- MASS-DIMM (~2yr)
- SODAR (~2yr)

Altitude (m)	25 percentile	50 percentile	75 percentile
0.0	8.06E-14	1.04E-13	1.40E-13
15.0	3.31E-14	5.32E-14	8.56E-14
30.0	1.60E-15	1.41E-14	2.10E-14
45.0	0.00	6.34E-16	1.03E-14
80-160	5.20E-16	7.27E-15	2.43E-14
160-240	0.0	3.51E-15	1.01E-14
240-320	0.0	2.91E-15	9.01E-15
320-400	0.0	1.87E-15	6.91E-15
400-480	0.0	4.10E-16	4.97E-15
480-560	0.0	0.0	1.67E-15
560-640	0.0	0.0	0.0
FA	2.46e-13	1.57e-13	9.37e-14

ground layer < 80m

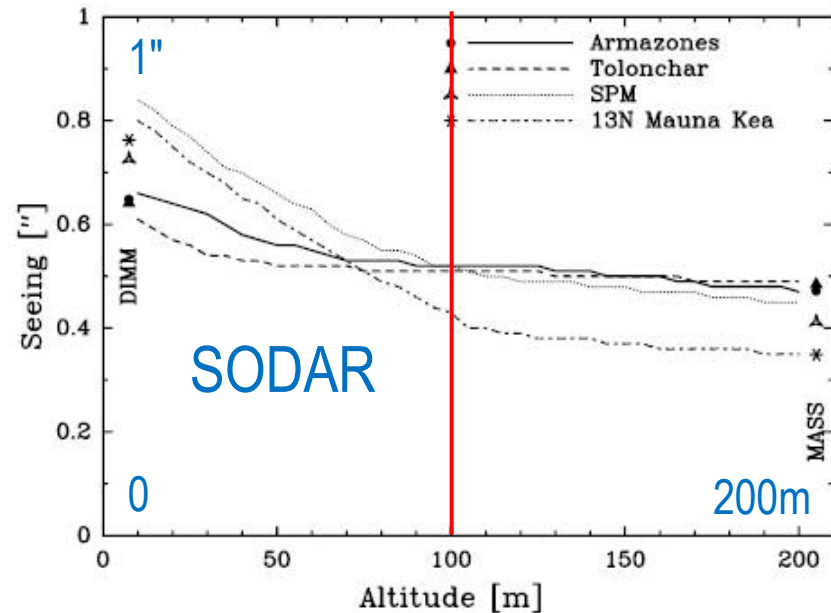

ground layer < 100m

# Seeing measurement plan at Subaru

## Local ground-layer at Subaru?

- **70m below** and **leeward** of the ridge (laminar flow?)
- fine resolution data for more detailed simulation

Luna Shabar (PTP)  
optical: 1 ~ 1000m

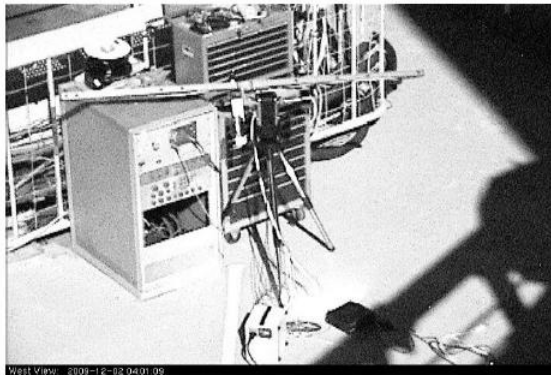
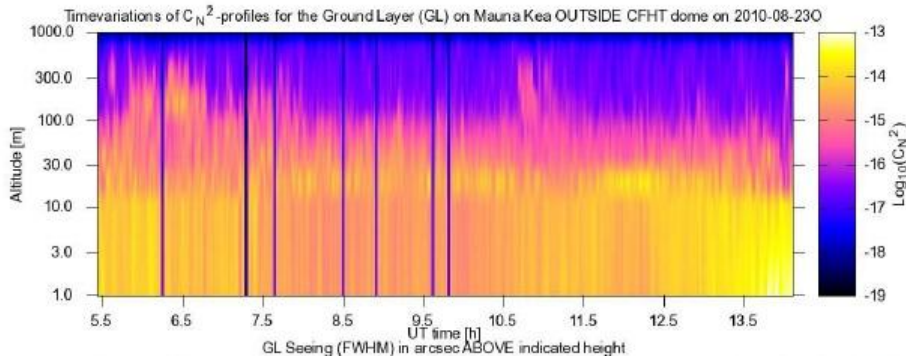

SNODAR  
acoustic: 10 ~ 100m

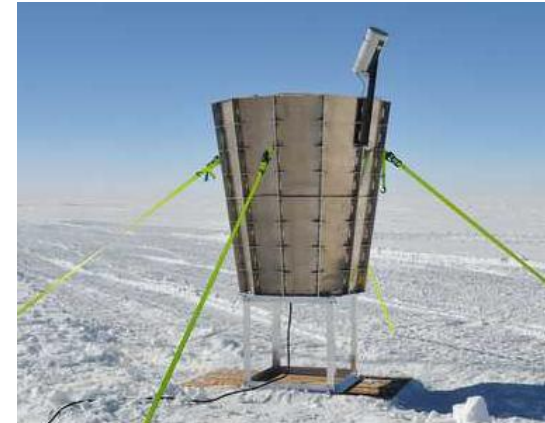
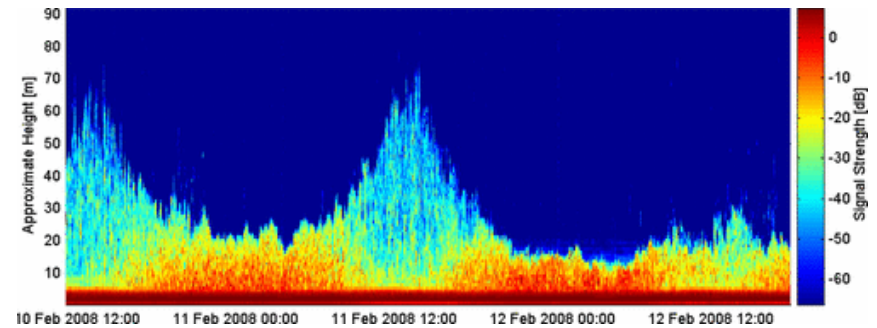

# RAVEN seeing model

D. Andersen "RAVEN modeling note: Model Atmosphere"

- based on **TMT site testing profile** at 13N (Els+09,PASP,121,527)

- **IQ statistics difference** between 13N profile and Subaru is attributed to ground layer

## Fractional Layer Strength

h km	seeing percentile		
	25%	50%	75%
$r_0$	19.4 cm	15.6 cm	12.1 cm
fwhm	0.53"	0.66"	0.85"
0	0.6823	0.5960	0.4971
0.5	0.0611	0.0963	0.1382
1	0.0212	0.0325	0.0577
2	0.0172	0.0372	0.0642
4	0.0757	0.0869	0.0833
8	0.0486	0.0684	0.0895
16	0.0939	0.0826	0.0700

increased to match  
Subaru IQ statistics

TMT site testing  
profile ratio

# Subaru GLAO configuration

tentative

$r = 5$  arcmin  
7.5 arcmin  
10 arcmin

DM: 32 act. Across  
@ -80m

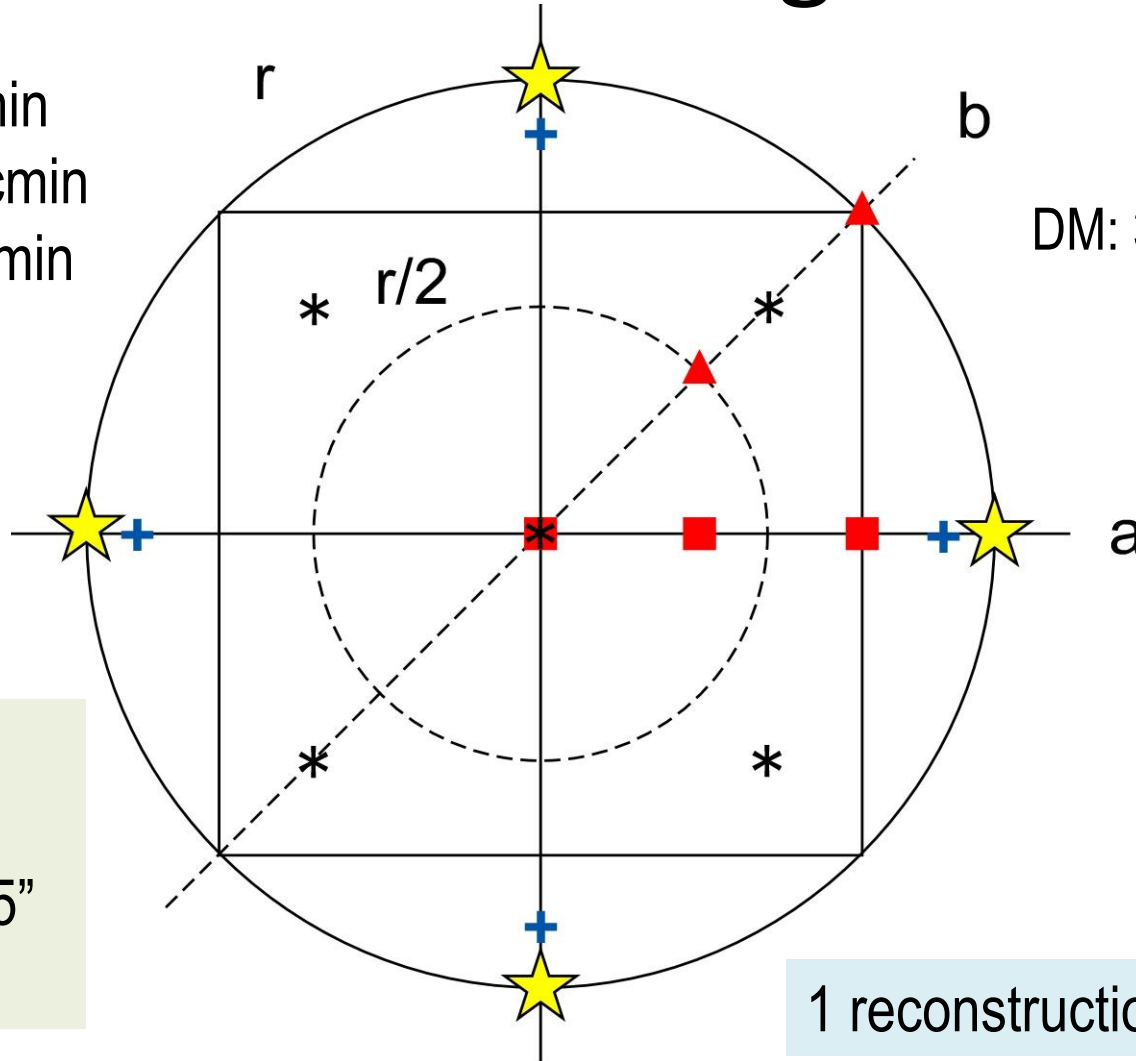

RAVEN seeing:  
- good: 0.52"  
- moderate: 0.65"  
- bad: 0.84"

★: HoGS +: TTF-GS (50" inside of LGS)

■: PSF eval.(toward GS) ▲: (between GS)

\* : DM fitting

# Seeing dependence of WFE

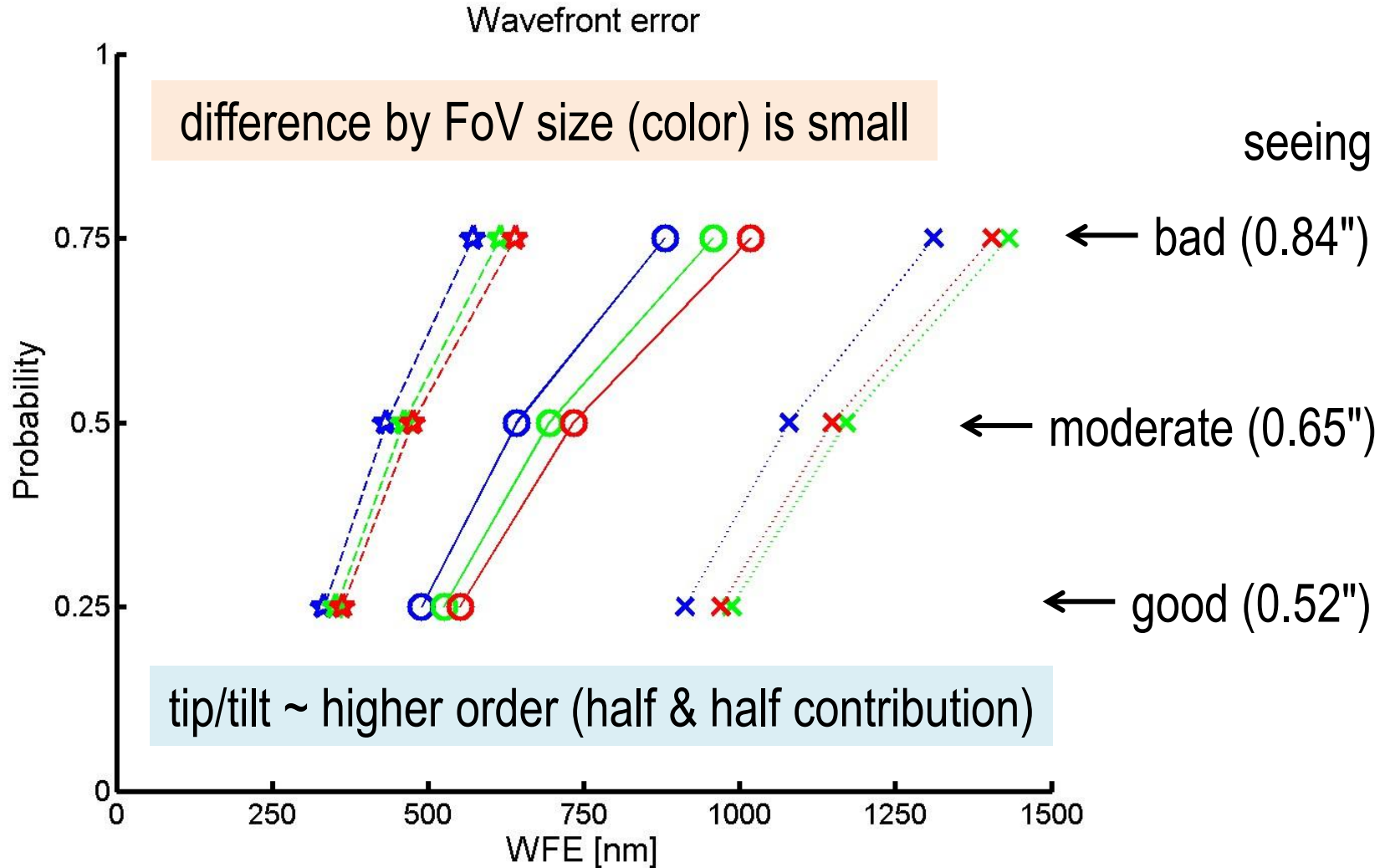

FOV: blue:  $\varphi = 10\text{arcmin}$ 、green:  $\varphi = 15\text{arcmin}$ 、red:  $\varphi = 20\text{arcmin}$

WFE order: ○: all order、☆: tip/tilt removed = higher order

Seeing: ×

# Seeing dependence of FWHM

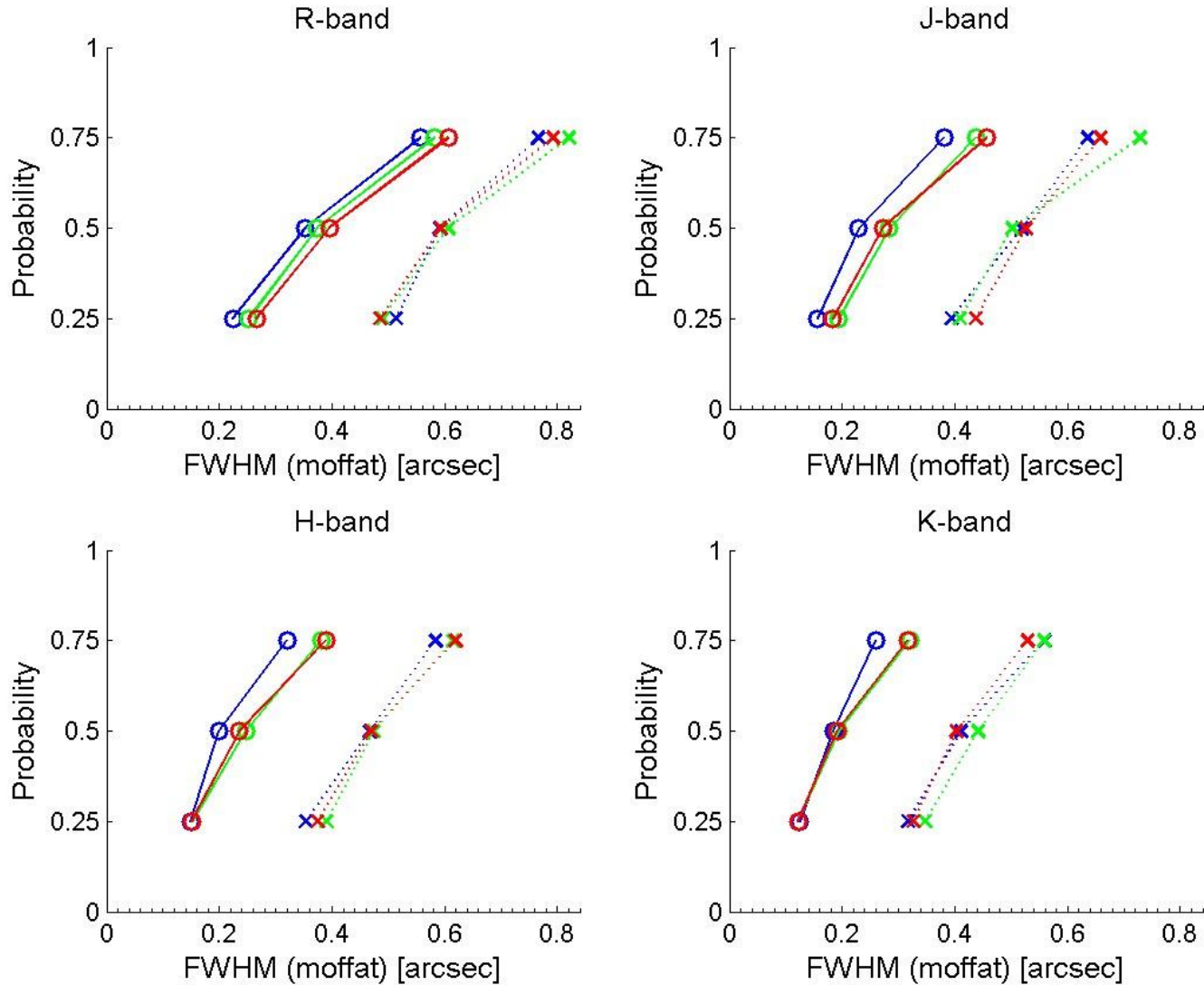

FOV: blue:  $\phi = 10$  arcmin, green:  $\phi = 15$  arcmin, red:  $\phi = 20$  arcmin  
GLAO: O, Seeing: x

# Seeing vs FWHM ratio (GLAO/seeing)

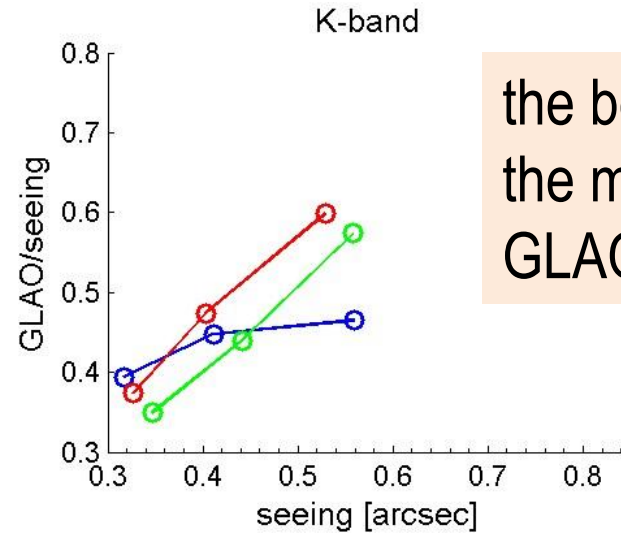
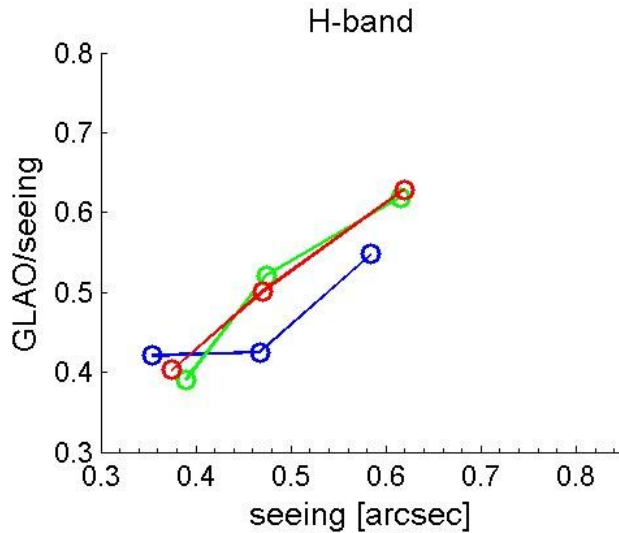
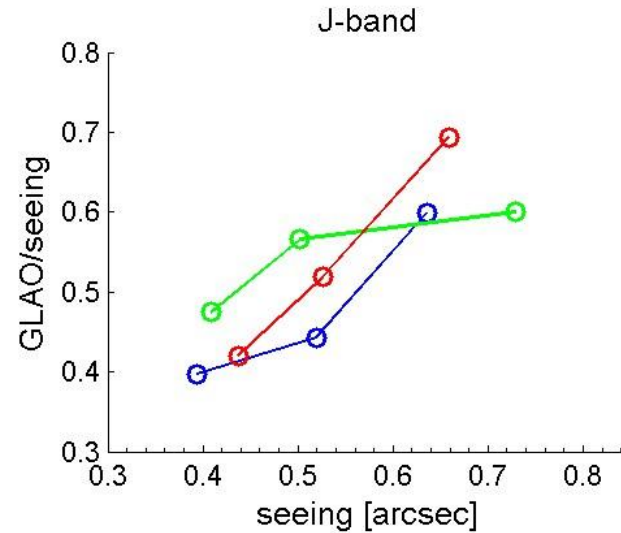
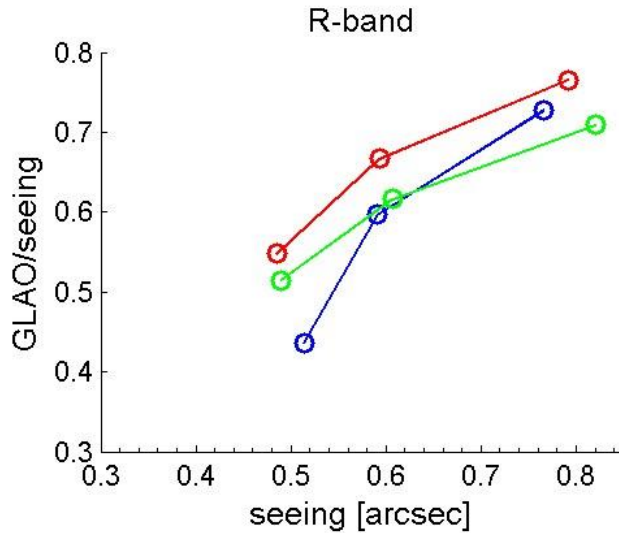

the better seeing is,  
the more effective  
GLAO correction is.

FOV: blue:  $\phi = 10$  arcmin, green:  $\phi = 15$  arcmin, red:  $\phi = 20$  arcmin

# Seeing vs EsqE ratio (GLAO/Seeing)

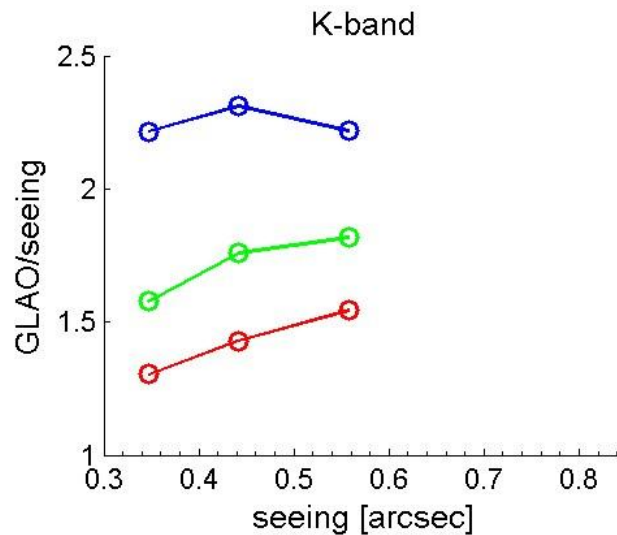
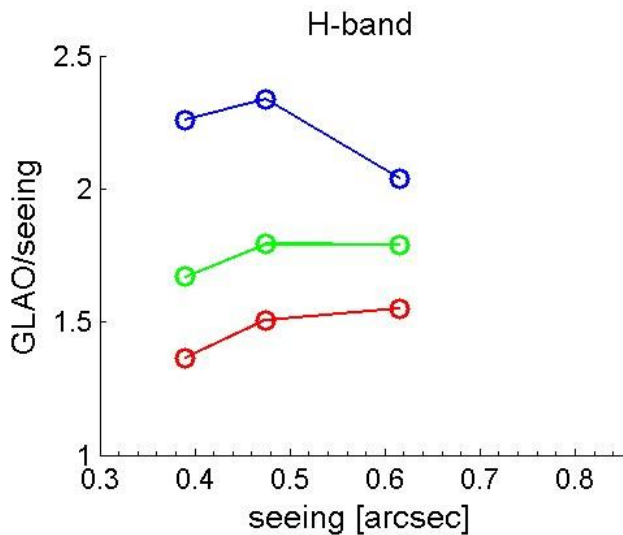
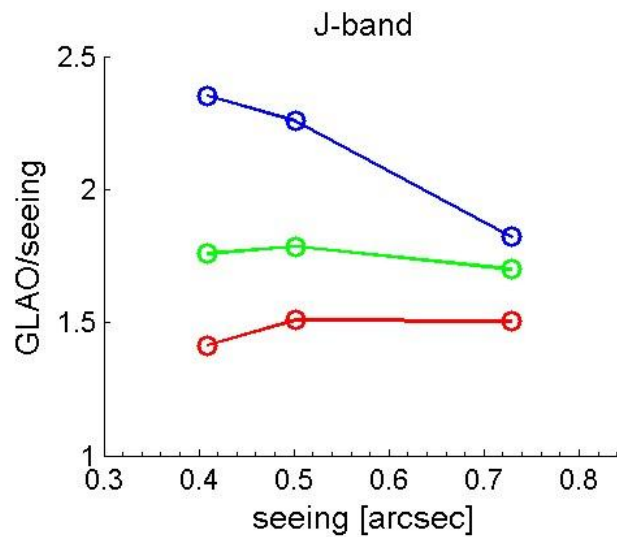
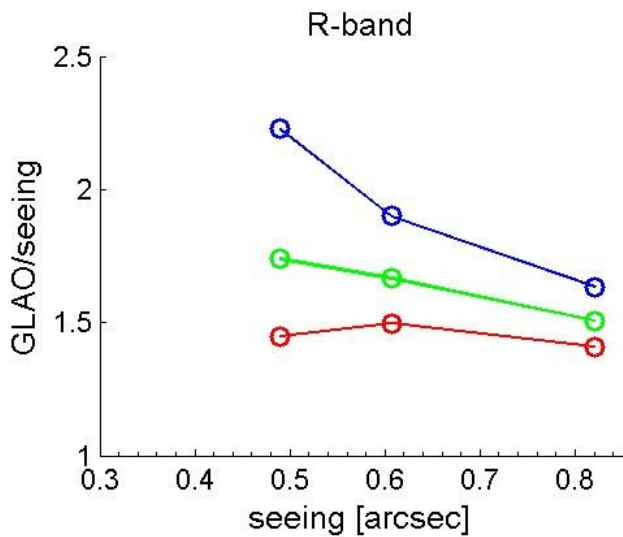

width: blue: 0.24"、green: 0.36"、red: 0.48"

FoV: 15'  $\phi$

# Comments on the noise

Seeing:  $\sigma_{\text{total}}^2 = \sigma_{\text{atm}}^{\text{FA}} + \sigma_{\text{atm}}^{\text{GL}}$

FA: free atmosphere  
GL: ground layer

GLAO:  $\sigma_{\text{WFE}}^2 = \underbrace{\sigma_{\text{atm}}^{\text{FA}}}_{\text{uncorrected (dominant) seeing determines performance}} + \underbrace{(\sigma_{\text{sense}}^2 + \sigma_{\text{fit}}^2 + \sigma_{\text{delay}}^2 + \sigma_{\text{etc}}^2)}_{\text{corrected (residual of AO system error) performance little change if } \sigma_{\text{each}} < \sigma_{\text{atm}}^{\text{FA}}}$

## WFE ( $\sigma_{\text{WFE}}$ ) increase

- limit mag ( $\sigma_{\text{sensor}}$ ): 8% by R=18 (TTF, 10mag LGS), RN limit
- HoWFS order ( $\sigma_{\text{fit}}$ ): ~0% by 8x8 R=15  $\Leftrightarrow$  32x32 R=13
- frame rate ( $\sigma_{\text{delay}}$ ): 8% by 200Hz  $\Rightarrow$  50Hz (gain=0.5)

# Bright NGS vs Typical LGS

typical case: moderate seeing (0.66"), FoV 15'φ

WFE [nm]: Tot: **1274** ± 325, TT: 955 ± 395, Ho: 802 ± 129

- NGS sensor noise free (R=10)

WFE [nm]: Tot: **737** ± 95, TT: 515 ± 122, Ho: 519 ± 47

- LGS R=10, NGS(TTF) R=18mag

WFE [nm]: Tot: **783** ± 127, TT: 578 ± 161, Ho: 517 ± 47

WFS parameters: SH, 200Hz, gain=0.3, RN=0.1e-, 512x512pix

# Possible observation modes by ASM

## 1. GLAO @ Cs

- seeing improvement over wide FoV

## 2. On-Source Single NGS @ Cs, Ns

- high SR for bright on-source NGS
- reduction of thermal background at  $\lambda > 2\mu\text{m}$

## 3. Single Conjugate Laser Tomography (SCLT) @ Cs, Ns

- better SR than on-source single LGS
- as close to on-source single NGS as possible

- Multi-Conjugate Laser Tomography (MCLT)?

- to increase FoV  $> 1$  arcmin

# 14. On-source bright NGS

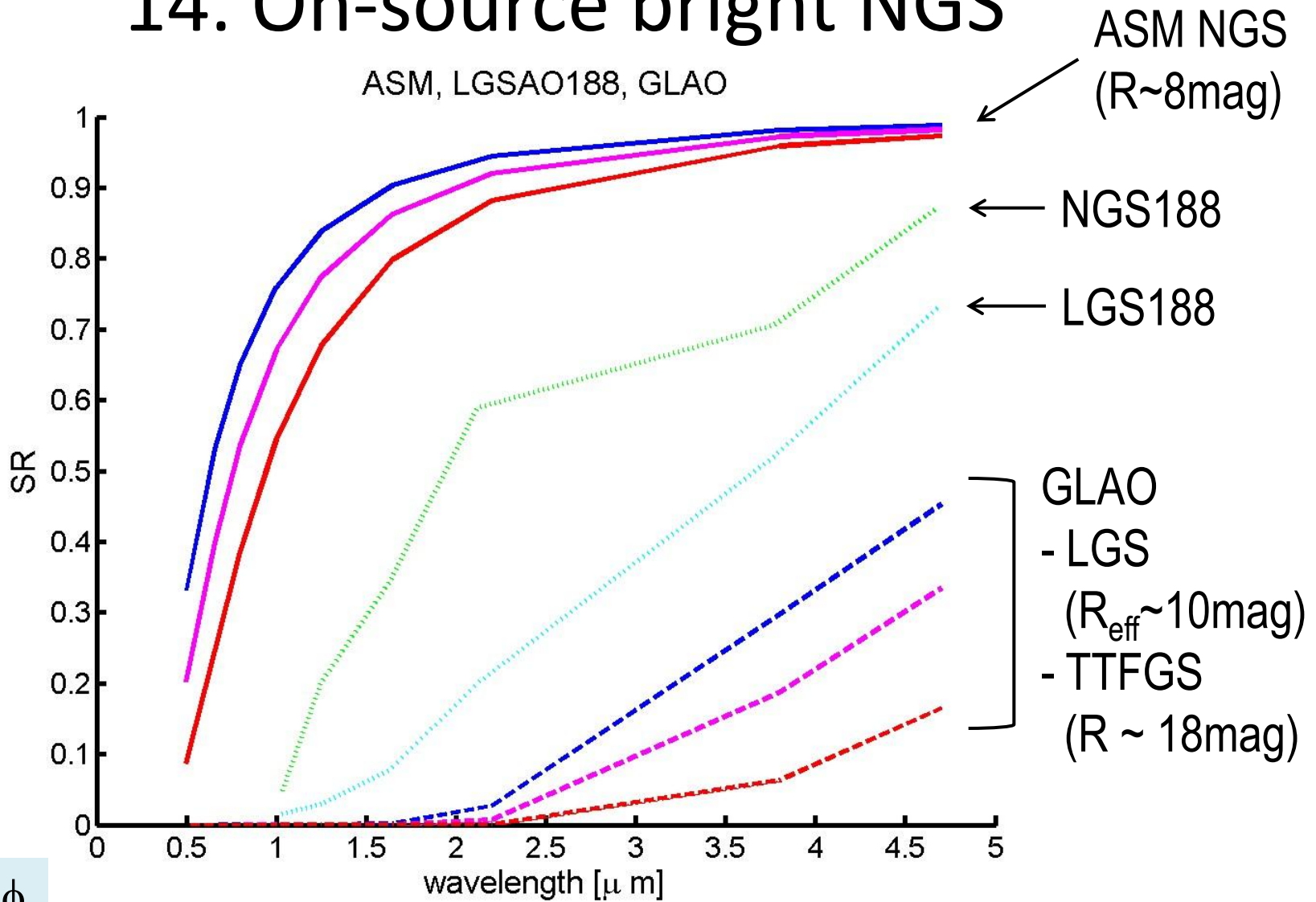

FoV: 15'  $\phi$

Seeing @ 0.5 $\mu\text{m}$ : good (0.52"), moderate (0.62"), bad (0.84")

System: solid: ASM, dashed: GLAO, LGSAO188: GLAO

# Summary

- GLAO: Ground Layer Adaptive Optics
  - a wide-field AO correcting ground-layer turbulence only
  - Mauna Kea seeing is suitable for GLAO
- Expected performance of GLAO by MAOS simulation
  - Seeing model: TMT (13N) + GL to match Subaru IQ statistics
  - Parameters: 32 elem, 4GS (NGS or LGS+TTF), 200Hz, 0.1e-RN
  - Correction
    - FOV: 15'  $\Phi$ , FWHM < 0.2" @ K-band: 50%ile; 0.65" @ 0.5 $\mu$ m
  - Field-of-View
    - mechanical vignetting by the telescope & optical design of the instrument limit FoV (not GLAO performance)
- Other possible observation modes by ASM
  - On-source bright NGS
    - FOV: 1'  $\Phi$ , SR  $\sim$  0.9 @ K-band : 50%ile; 0.65" @ 0.5 $\mu$ m
  - Laser tomography
    - single conjugate (ASM only), multi conjugate (in future?)

# Appendix

# Future Work

- Seeing measurement at Subaru site
- Optimization of GLAO configuration (field setup)
-

# Why Wide-Field AO?

- Subaru has seeing-limited wide-field instruments
  - synergy: data / science
  - rigid structure: prime focus / exchangeable 2ndry
- Relation to other telescopes
  - 8m-class telescopes have a wide-field AO plan
  - complementarity with 30m-class telescopes  
(light-collecting power and angular resolution of 8m-class will be not attractive any more)

# AO zoology over the world

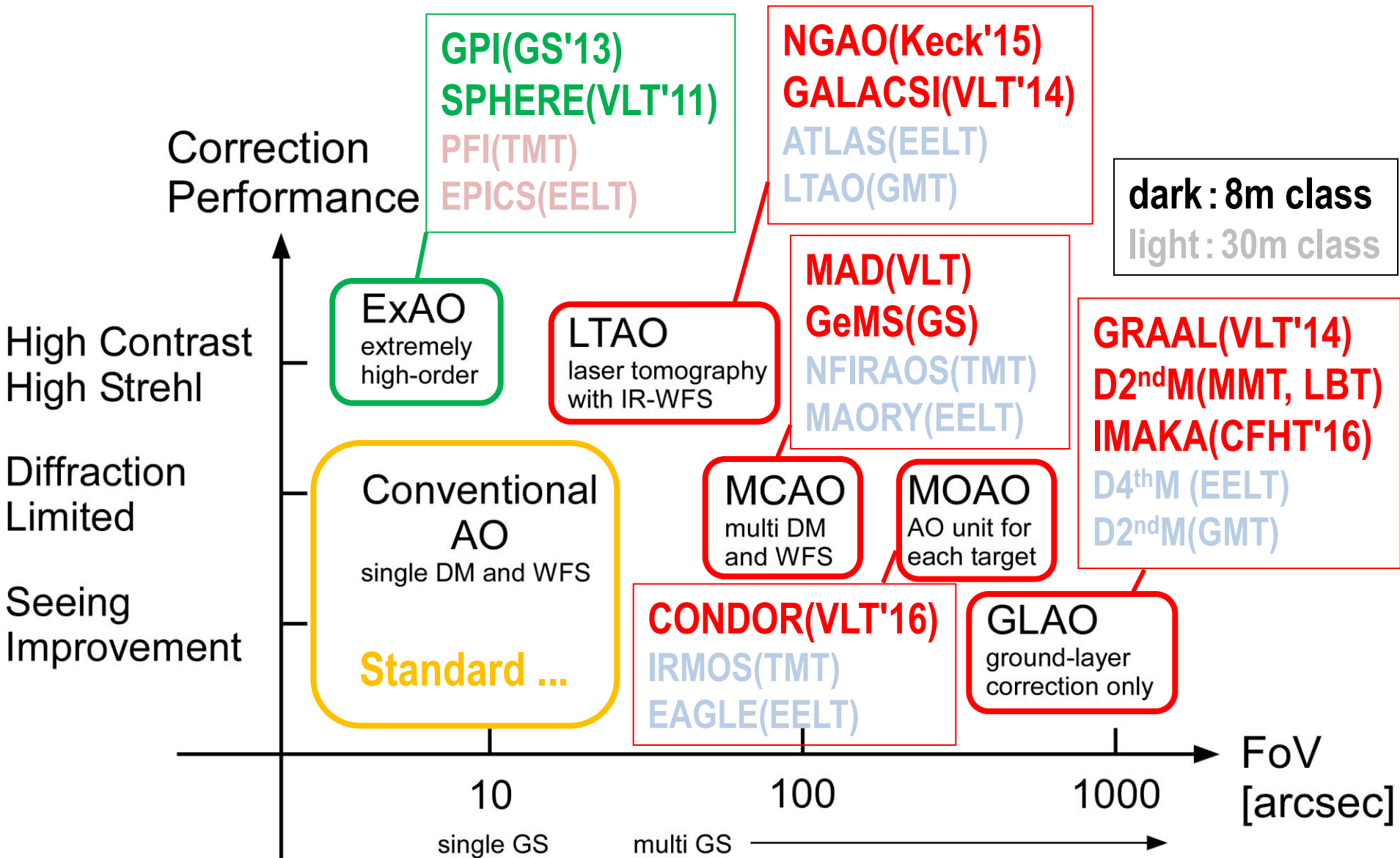

# Wide Field AO: MCAO



FoV: 2 arcmin  
diffraction-limited  
survey possible

multiple layers  
&  
multiple correctors

conjugated

multiple WFSs

wide-field instrument

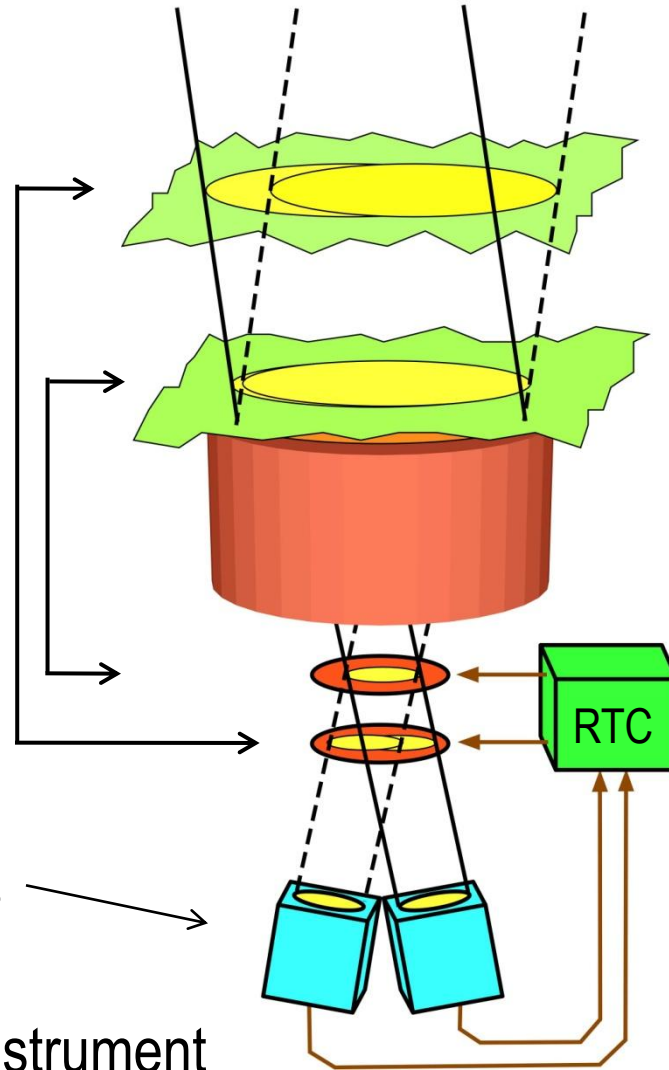

# Wide Field AO: GLAO

FoV: 10 arcmin  
fwhm: < 0.4 [arcsec]  
survey possible

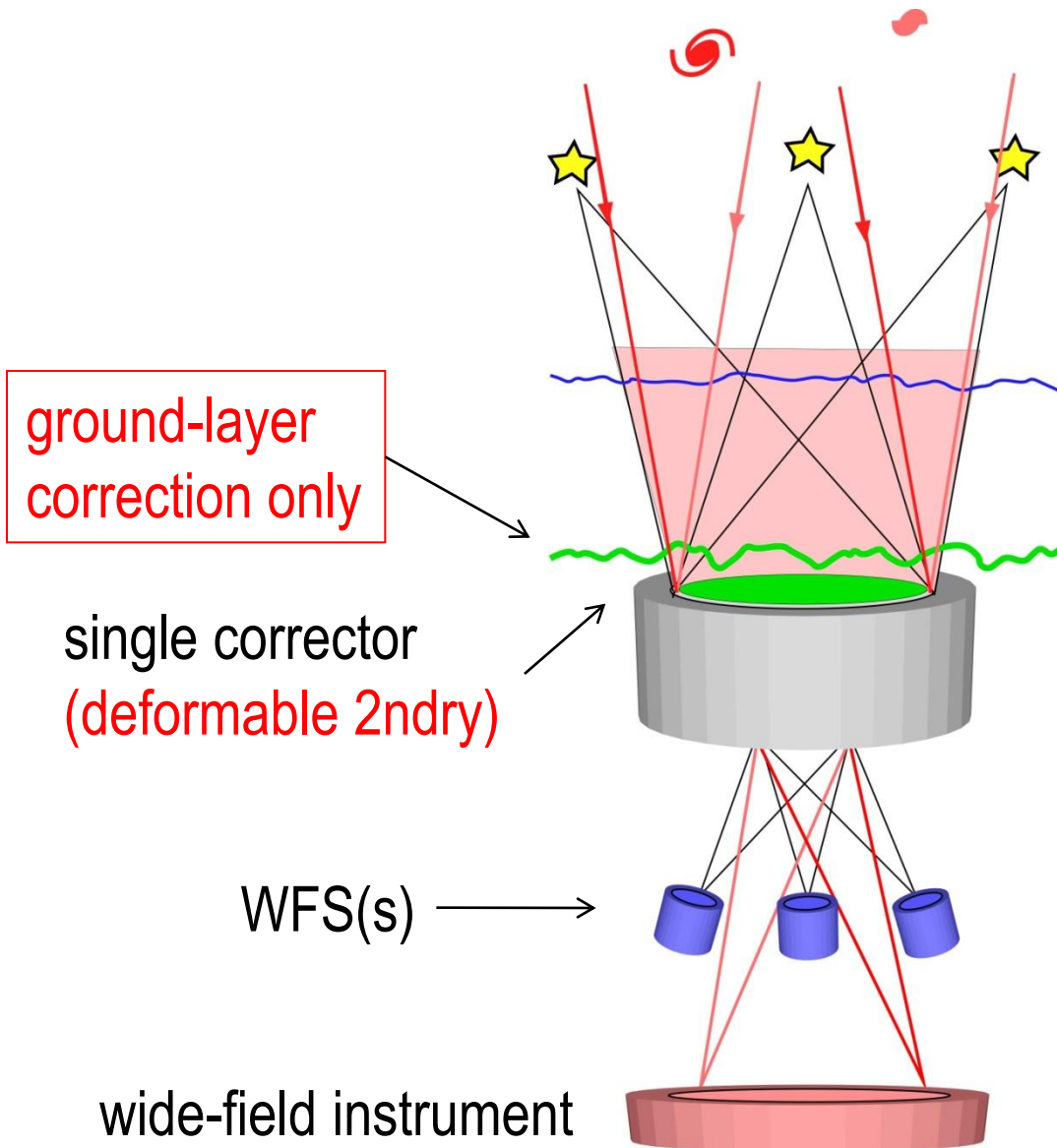

# Wide Field AO: MOAO

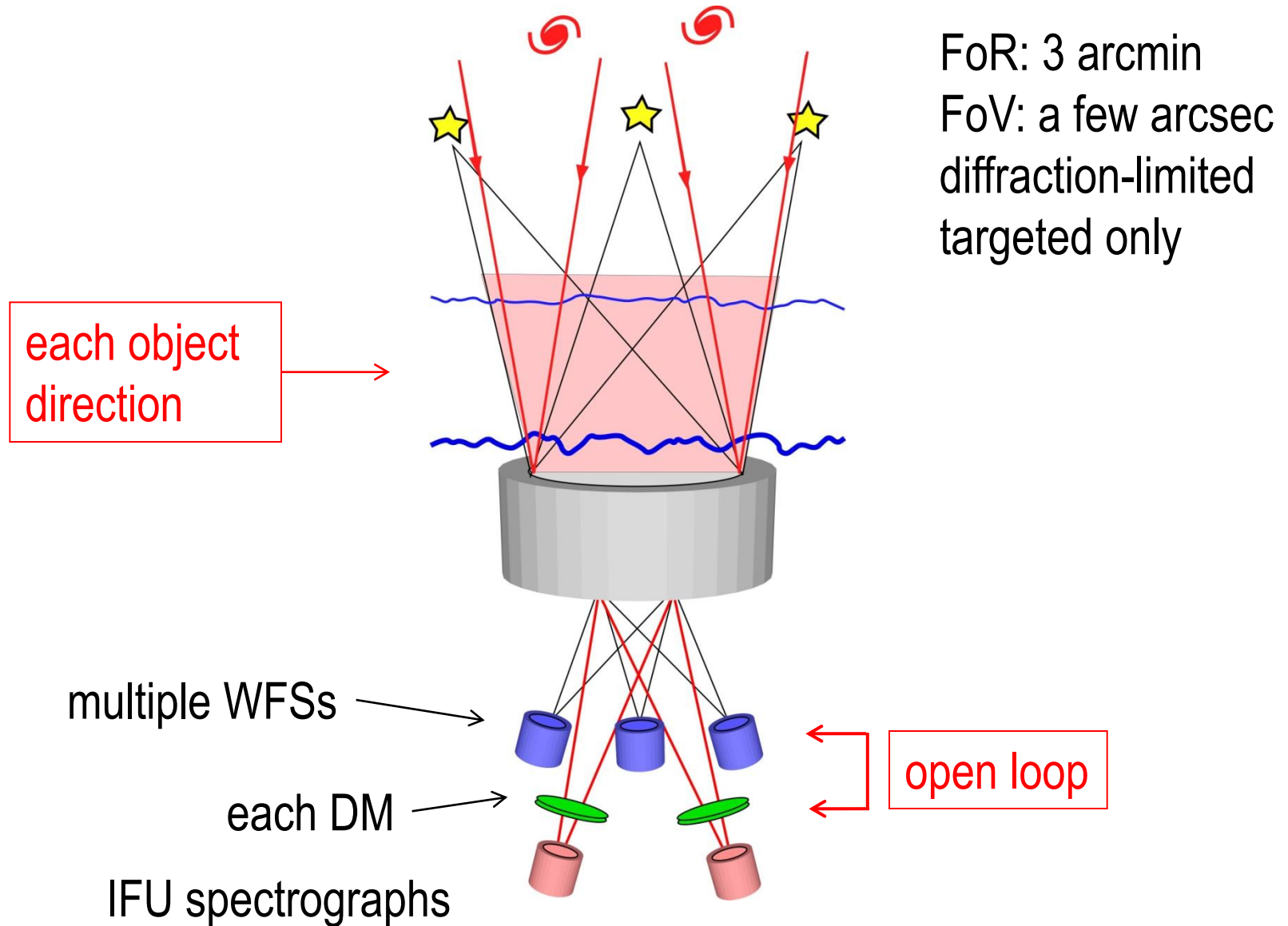

# Reduction of cone effect: LTAO

AO tomography: measure turbulence and correct for “cone effect”



one laser guide star

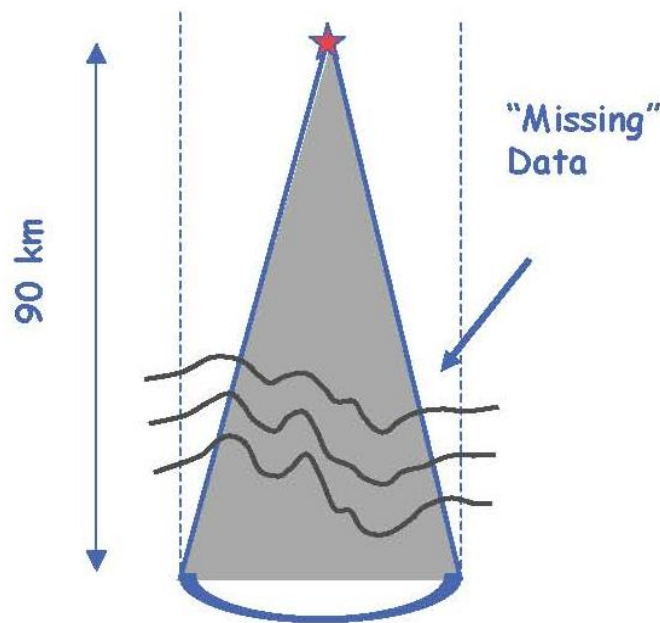

Without tomography

multiple laser guide stars

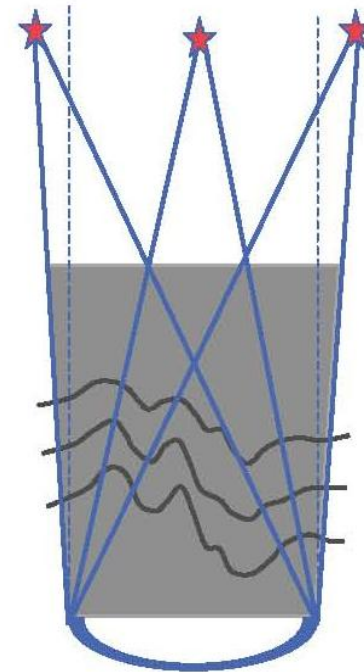

With tomography

With AO tomography, measure 3D distribution of turbulence above telescope

# Mauna Kea seeing: overall profile

- Free atmosphere turbulence: weak
- Ground layer turbulence: strong

suitable for  
GLAO

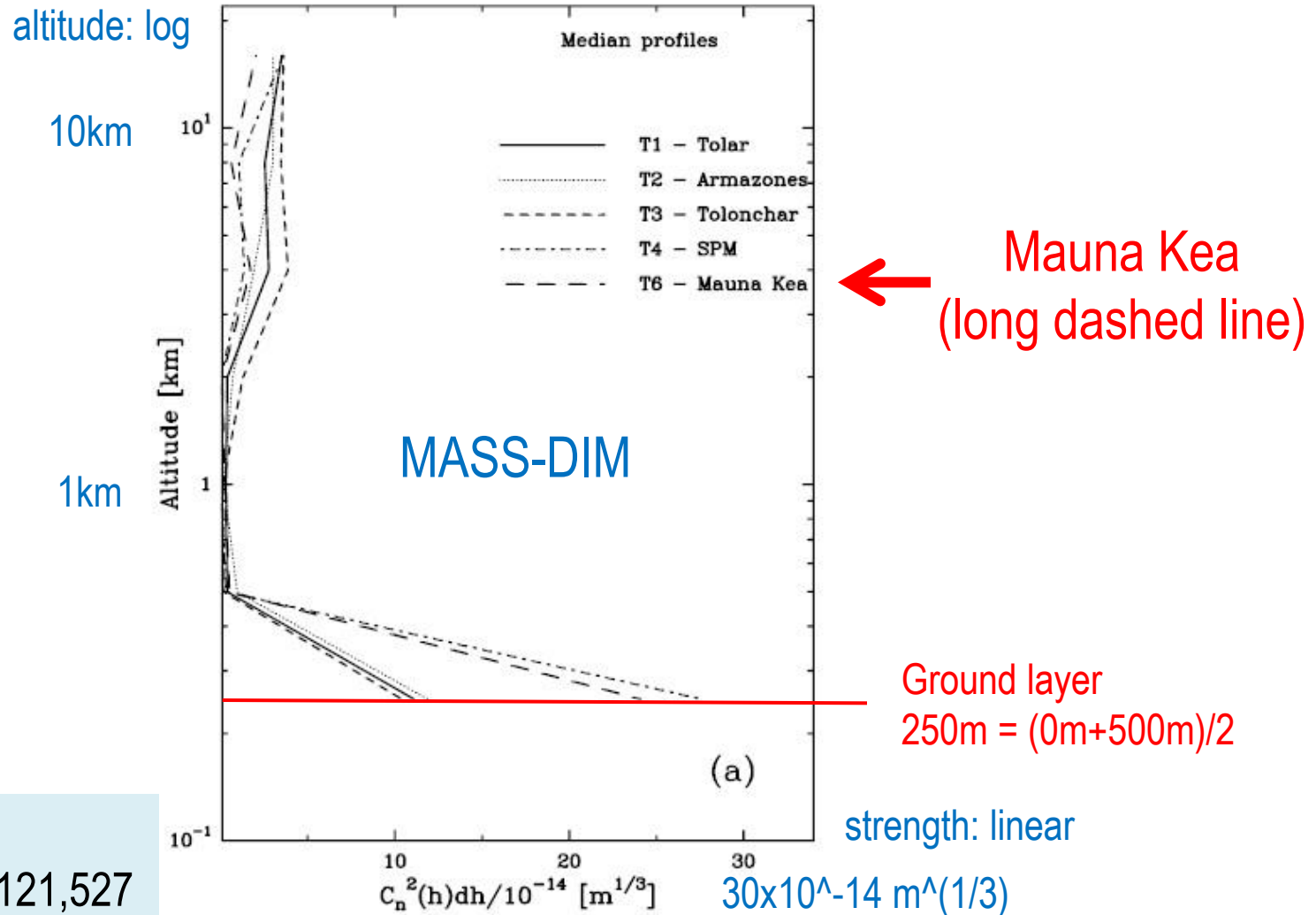

# Comparison of simulation codes

## Comparison with Gemini GLAO simulation (Appendix F1)

validation of MAOS configuration: compared with other

check influence of gray-zone: same seeing (0.6" @ 0.5um), but different height (300m, 500m, 900m) and strength of gray-zone

### MAOS additional conditions

wind speed: 6.5m/s @ < 1km, 15m/s @ 2km, 30m/s @ 10km (IMAKA model) ; direction: random

DM fitting: 10' square 5 points: (0' ,0'), (+/-5', +/-5')

Gain: 0.3

Noise free

MAOS

### FWHM

Code	Star Pos.	UA code 1	UA code 1	UD code	PAOLA	CIBOLA			(Gauss)	(Moffat)	MAOS		
Profile	[arcmin]	[arcsec]	[arcsec]	[arcsec]	[arcsec]	[arcsec]	ave	std	[arcsec]	[arcsec]	beta	ave	std
Uncorrected		0.359	0.357	0.353	0.349		0.355	0.004	0.347	0.340	3.083	0.344	0.005

### low gz

1	(0.0, 0.0)	0.258	0.224	0.235	0.221	0.220	0.235	0.017	0.215	0.209	1.70	0.212	0.004
1	(2.5, 0.0)	0.254	0.225	0.247	0.227	0.214	0.238	0.014	0.230	0.228	4.17	0.229	0.001
1	(5.0, 0.0)	0.256	0.228	0.252	0.230	0.214	0.242	0.015	0.234	0.227	1.62	0.231	0.005
1	(2.5, 2.5)	0.247	0.224	0.233	0.216	0.219	0.230	0.013	0.235	0.229	2.35	0.232	0.004
1	(5.0, 5.0)	0.263	0.222	0.253	0.235	0.230	0.243	0.018	0.250	0.246	2.66	0.248	0.003
ave		0.256	0.225	0.244	0.226	0.219	0.234		0.233	0.228	2.500	0.230	
std		0.006	0.002	0.009	0.007	0.007		0.015	0.013	0.013	1.031		0.012

### medium gz

2	(0.0, 0.0)	0.290	0.261	0.258	0.257	0.258	0.267	0.016	0.244	0.237	1.90	0.241	0.005
2	(2.5, 0.0)	0.282	0.260	0.263	0.261	0.252	0.267	0.010	0.262	0.259	5.77	0.261	0.002
2	(5.0, 0.0)	0.286	0.261	0.258	0.262	0.249	0.267	0.013	0.261	0.250	1.38	0.256	0.008
2	(2.5, 2.5)	0.282	0.257	0.258	0.251	0.255	0.262	0.014	0.243	0.243	1.80	0.243	0.000
2	(5.0, 5.0)	0.249	0.258	0.271	0.269	0.265	0.262	0.010	0.272	0.263	1.57	0.268	0.006
ave		0.278	0.259	0.262	0.260	0.256	0.263		0.256	0.250	2.484	0.253	
std		0.016	0.002	0.006	0.007	0.006		0.011	0.013	0.011	1.848		0.011

### high gz

3	(0.0, 0.0)	0.350	0.314	0.307	0.309	0.312	0.320	0.020	0.291	0.287	4.34	0.289	0.003
3	(2.5, 0.0)	0.336	0.314	0.310	0.312	0.307	0.318	0.012	0.301	0.300	5.33	0.301	0.001
3	(5.0, 0.0)	0.322	0.307	0.305	0.306	0.294	0.310	0.008	0.326	0.322	4.85	0.324	0.003
3	(2.5, 2.5)	0.334	0.311	0.305	0.304	0.305	0.314	0.014	0.312	0.306	2.97	0.309	0.004
3	(5.0, 5.0)	0.334	0.308	0.303	0.314	0.307	0.315	0.014	0.300	0.283	1.24	0.292	0.012
ave		0.335	0.311	0.306	0.309	0.305	0.313		0.306	0.300	3.746	0.303	
std		0.010	0.003	0.003	0.004	0.007		0.013	0.013	0.016	1.656		0.014

# 3. Seeing simulation

(1) MAOS calculation reproduces seeing @ 0.5  $\mu\text{m}$ , if FWHM is scaled by 1.22

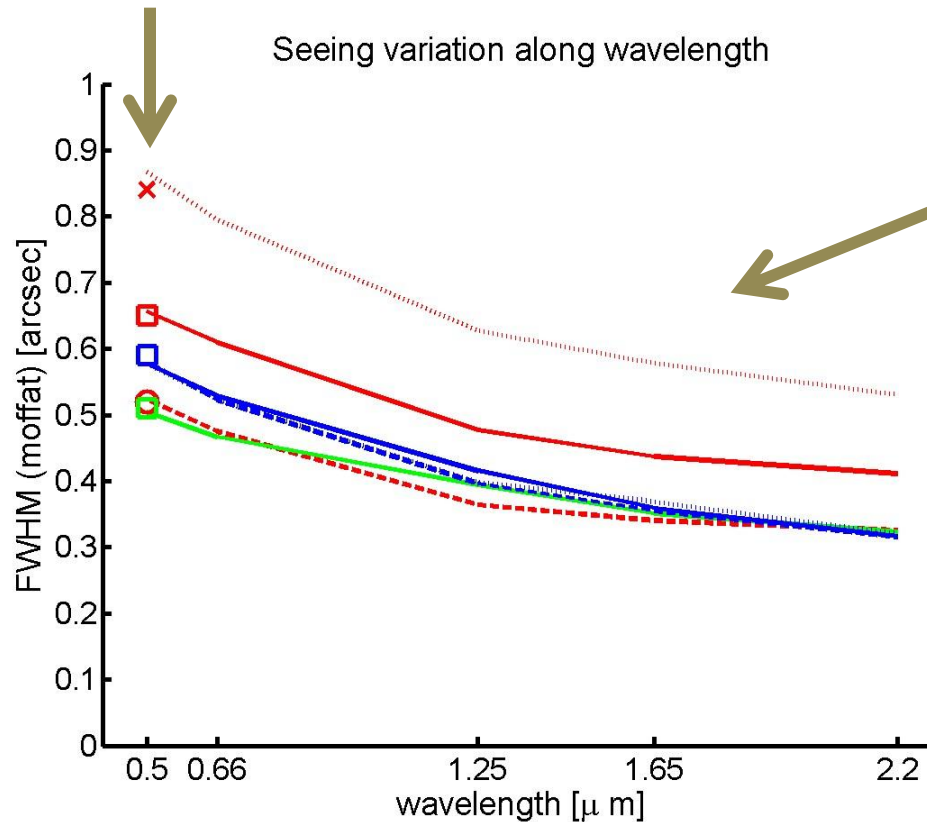

(2)  $\lambda$  dependence  
seeing  $\propto \lambda^{-0.2}$   
fitting:  $-0.3 \sim -0.4$   
i.e., under estimate at longer wavelength

RAVEN is used for Subaru simulation

red: RAVEN: good(dashed; r0  $\bigcirc$ ), moderate(solid; r0  $\square$ ), bad(dotted; r0  $\times$ )  
blue: Gemini: low gray-zone(solid), mid gz(dashed), high gz(dotted); r0  $\square$   
green: IMAKA: moderate(solid); r0  $\square$

# 8. Seeing WFE vs WFE ratio (GLAO/Seeing)

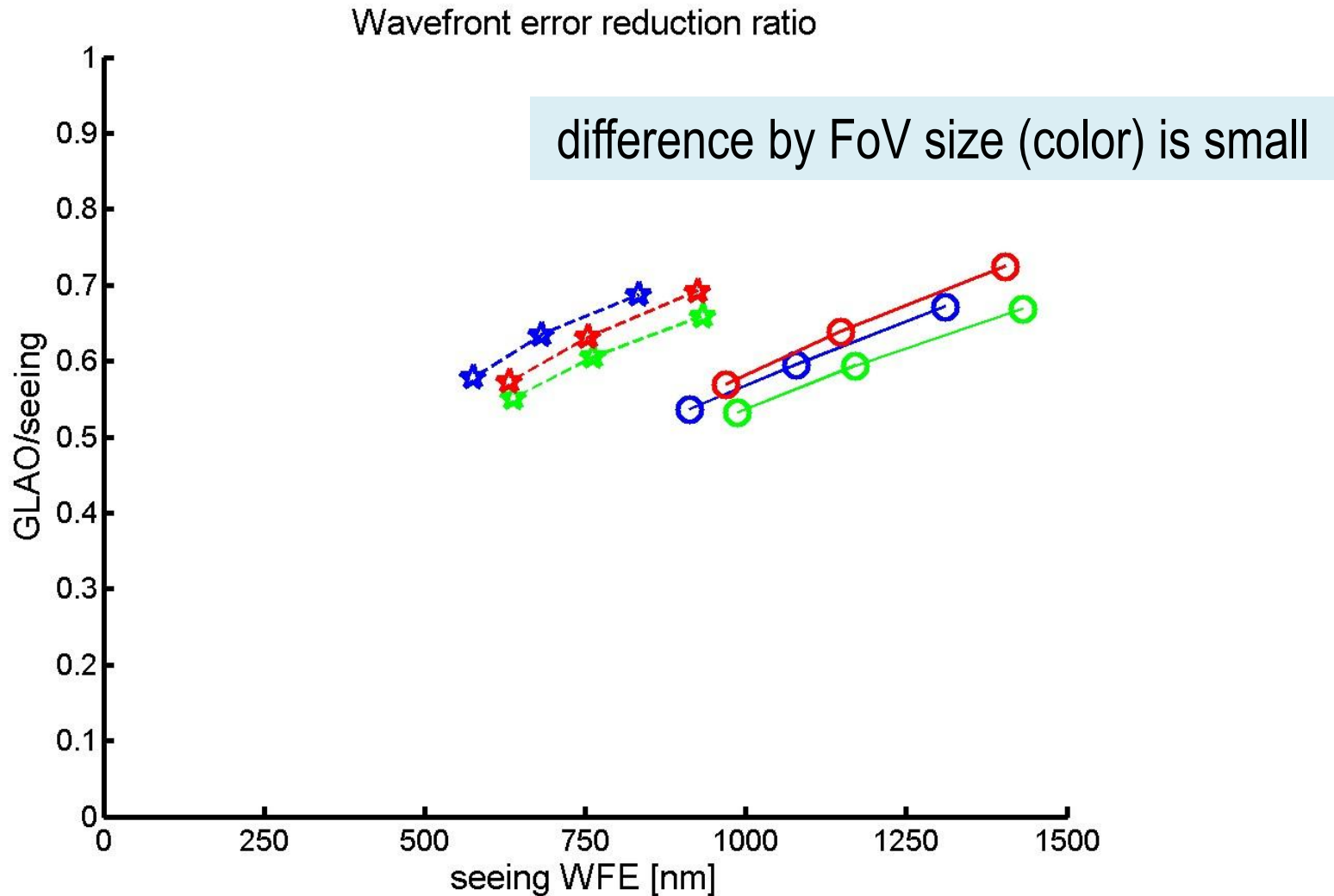

FOV: blue:  $\phi = 10$  arcmin、green:  $\phi = 15$  arcmin、red:  $\phi = 20$  arcmin

Order:  $\bigcirc$ : all order、 $\star$ : piston/tip/tilt removed = higher order

# 7. Seeing dependence of EsqE

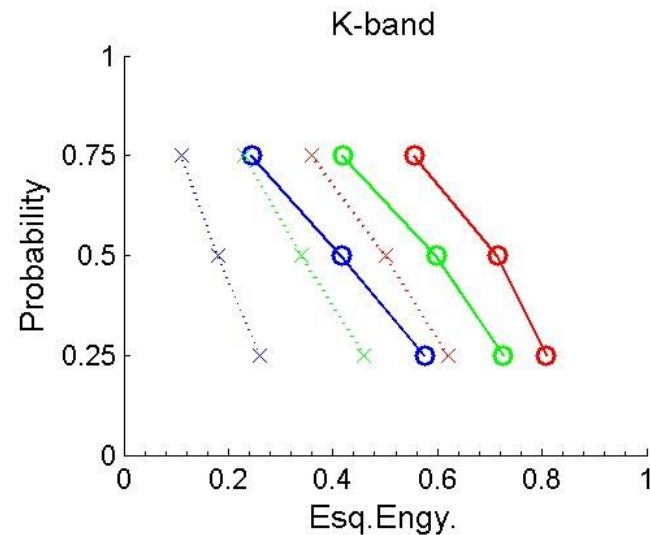
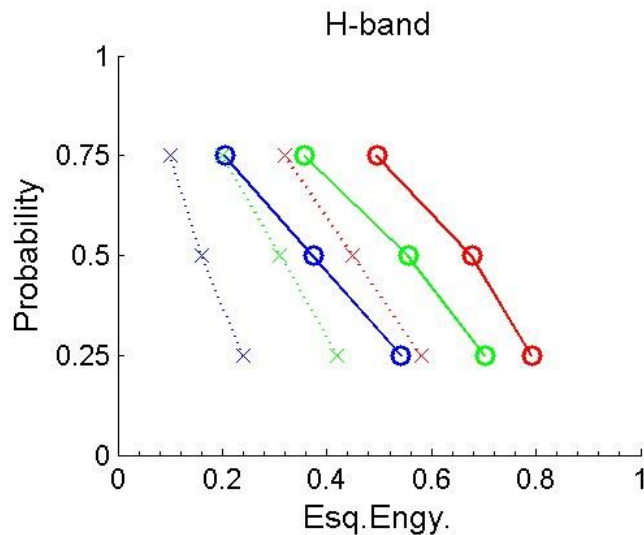
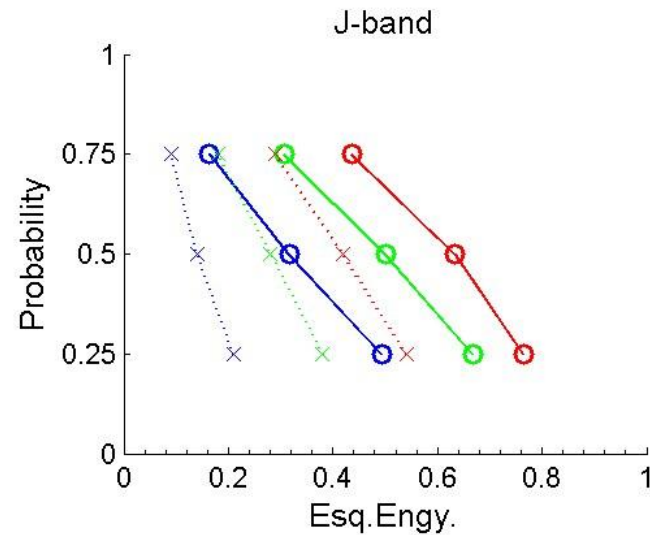
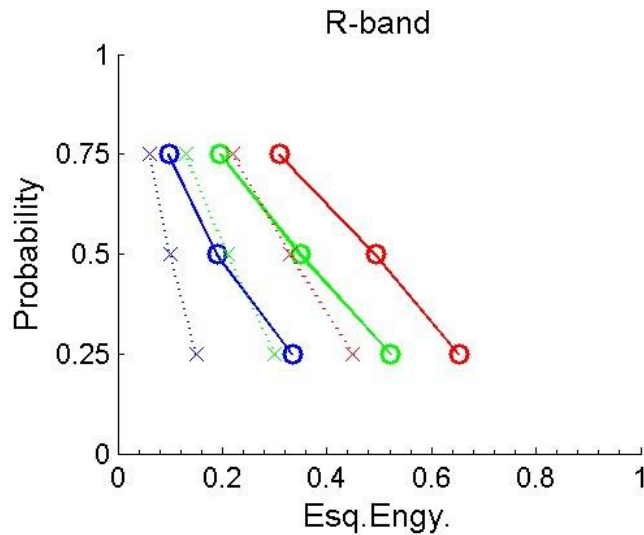

width: blue: 0.24"、green: 0.36"、red: 0.48"

GLAO: O、Seeing: x

FoV: 15'  $\phi$

# 11. Field dependence of WFE

Good seeing (0.52")

Moderate seeing (0.62")

Bad seeing (0.84")

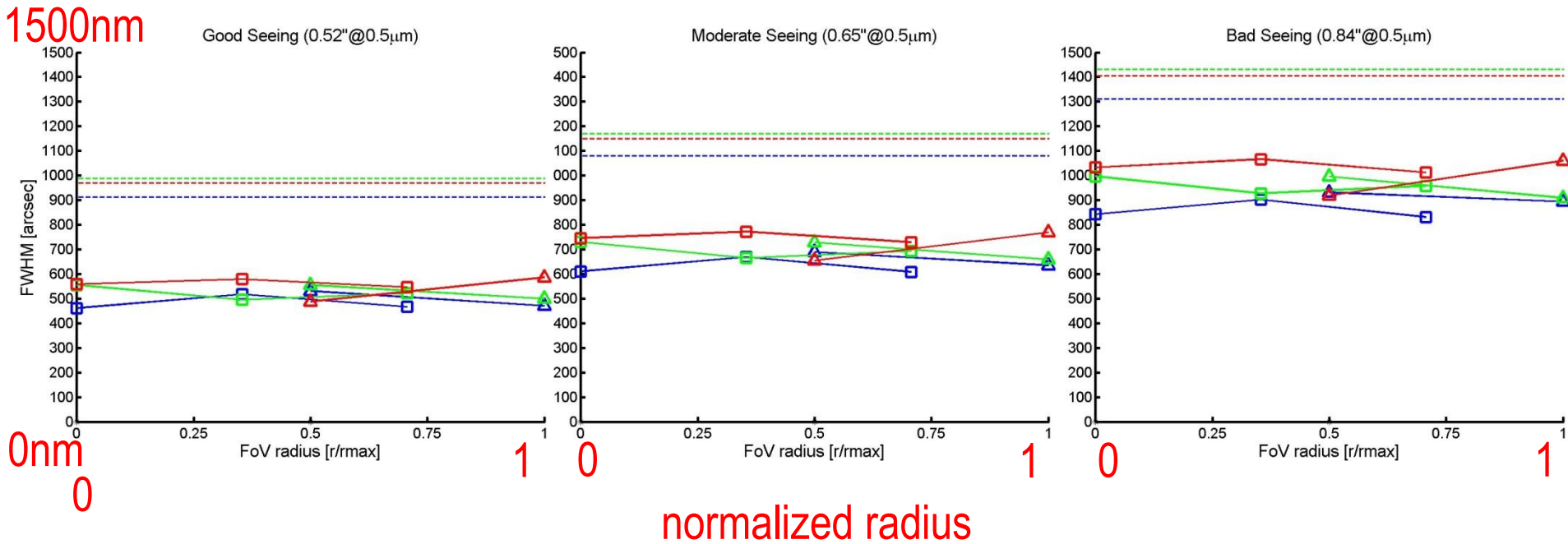

FoV: blue: 10'  $\phi$  、 green: 15'  $\phi$  、 red: 20'  $\phi$

direction:  $\square$ : toward GS、  $\triangle$ : between GS

GLAO: solid lines、 seeing (uncorrected): dotted lines

# 12. Dependence on the system order

FoV: 15'  $\phi$   
moderate  
seeing

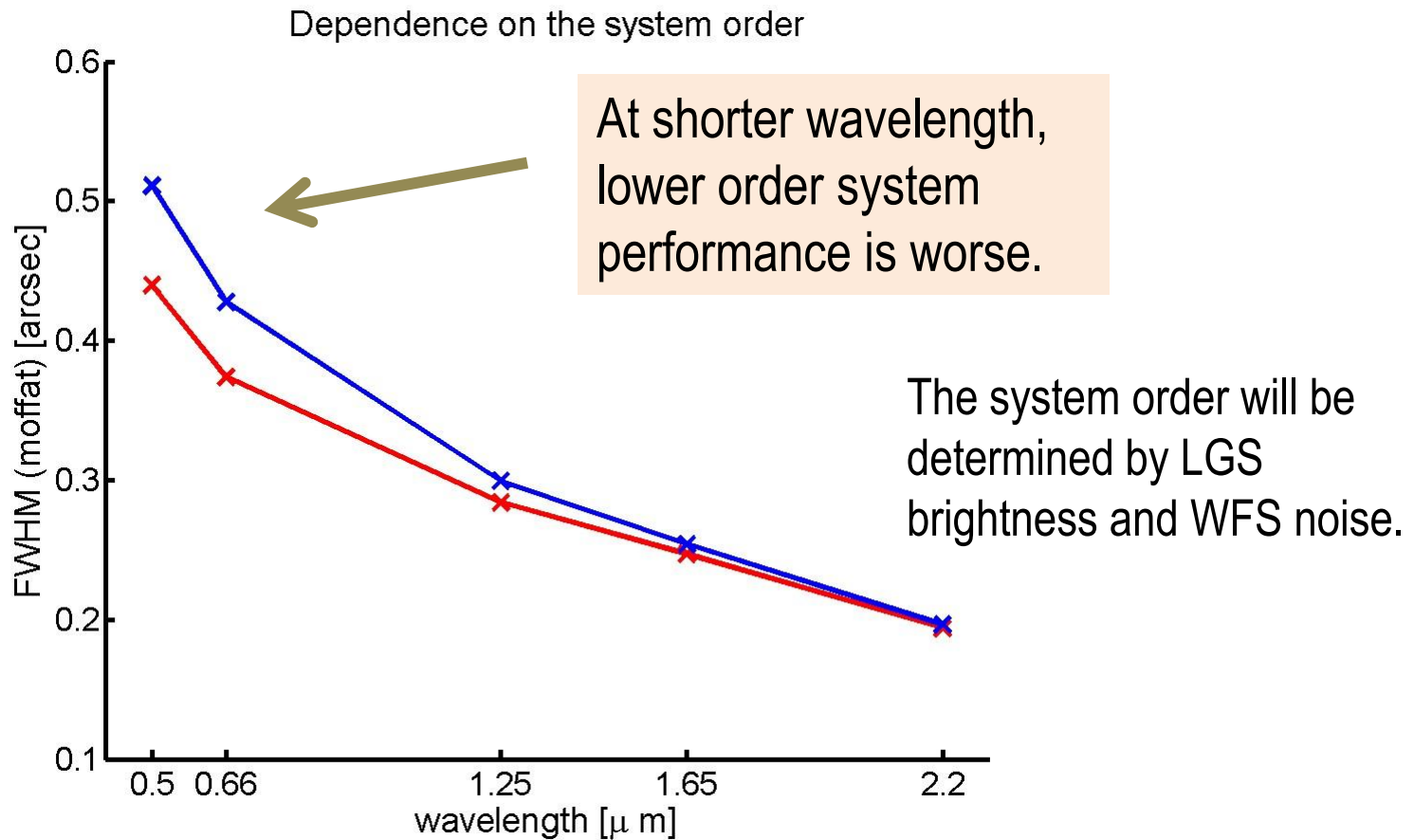

red: 32 act. across DM (& WFS)、blue: 10 act. across DM (& WFS)

Note that the result for the combination of high-order DM (32 act. across) and low-order WFS (10 act. across) is the same as 10 act. across DM (&WFS).

# RAVEN

Test bed at 8m telescopes, expansion to the 30m telescopes

open-loop test was successful  
on-sky tomography is not yet  
1st light: 2013 ~

FoR: 2'  $\phi$   
SR: 0.4 @ H-band

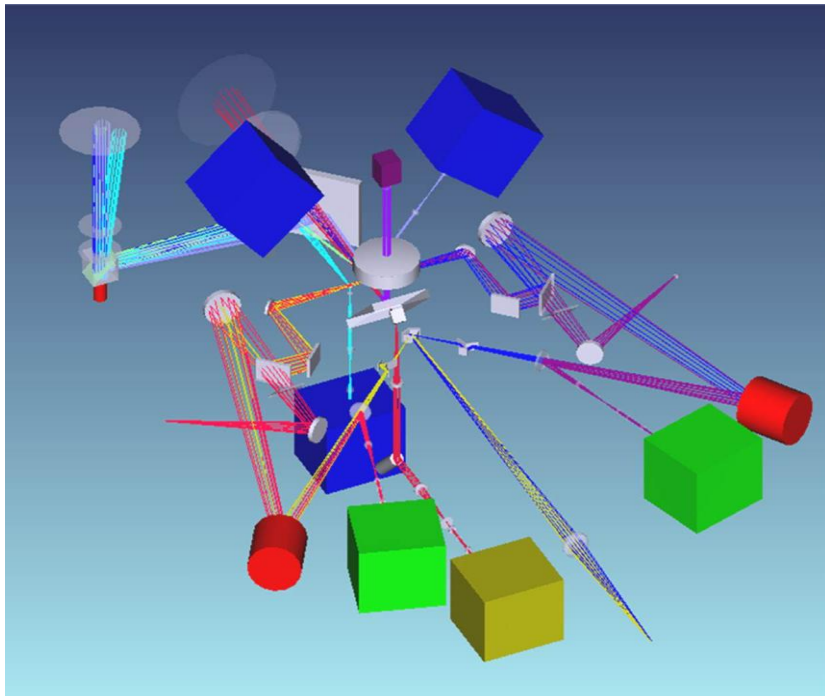

WFE  
[nm]

300

150

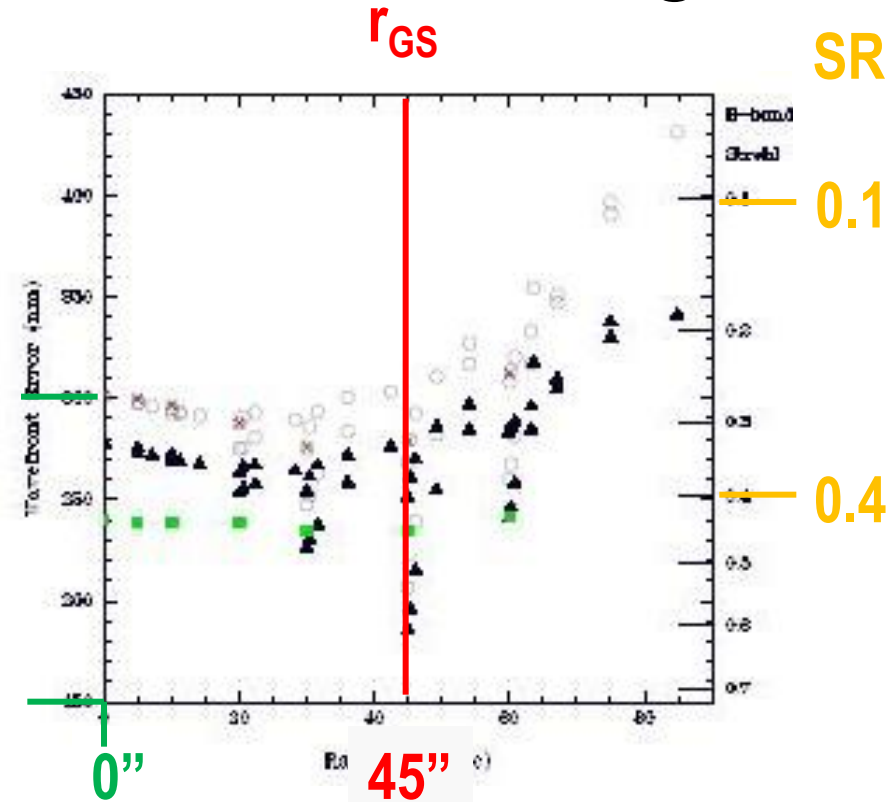

X-axis: separation from the center of FOV in arcsec  
Y-axis left: WFE in nm: ○ all modes; ▲ TT removed  
right: SR × ; ■ EE

# MOAO: Fieldd-of-Regard

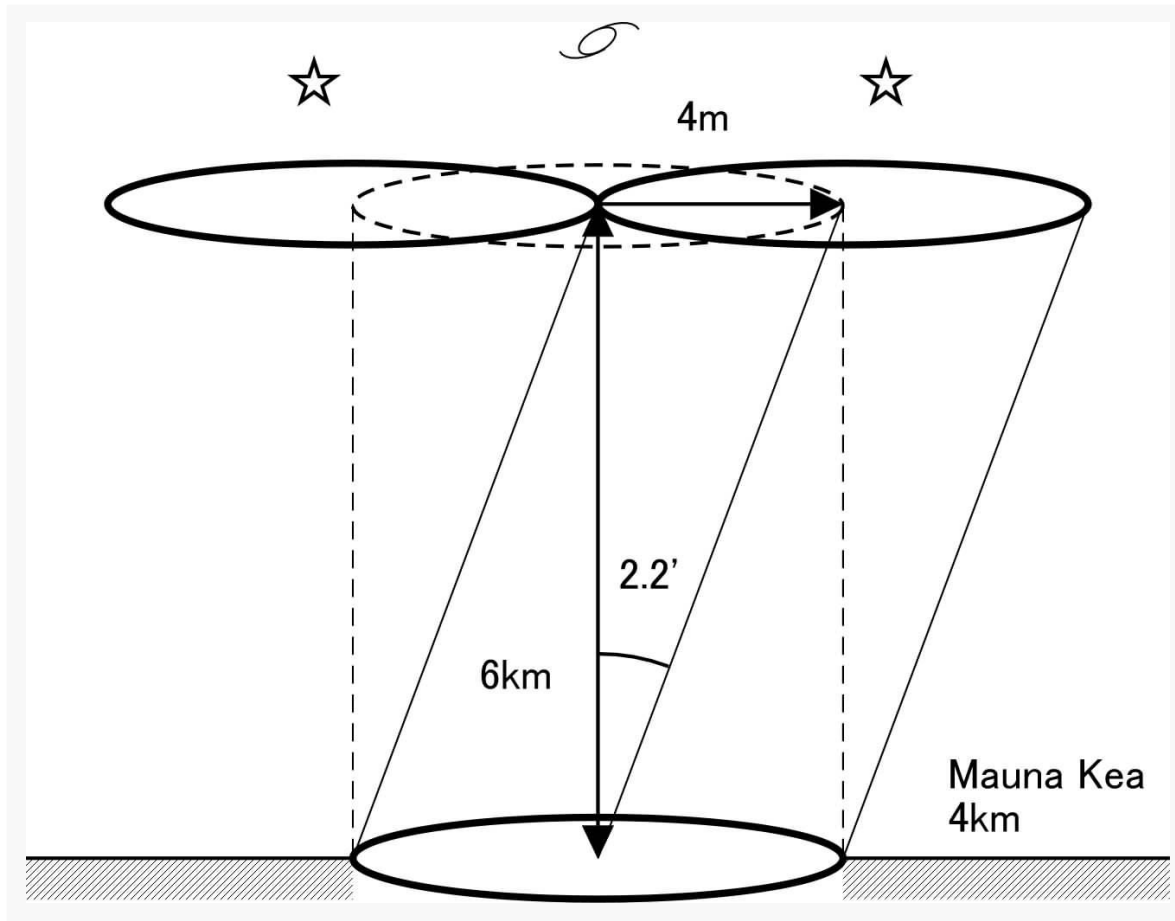

ビームの重なり  
(meta pupil)  
at 6km (top view)

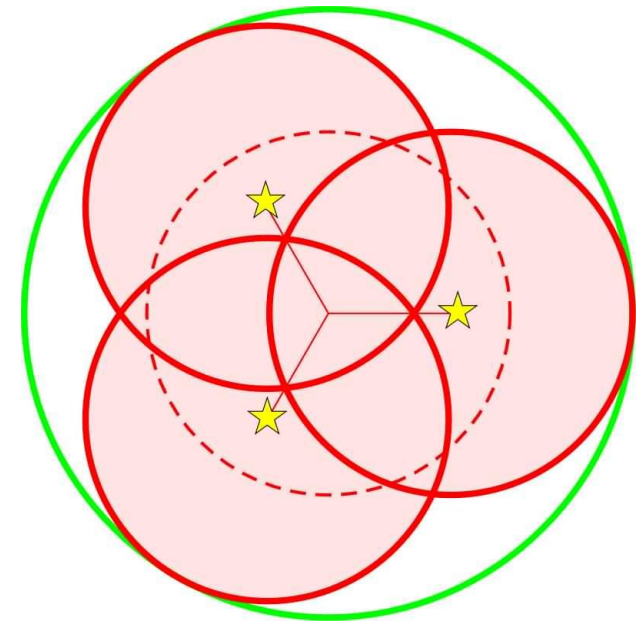

8m aperture

3arcmin FoR

3GS

# Wide Field AO in 30m Era

## GLAO

FoV: >10 arcmin  
Improving seeing  
(fwhm: ~ 0.2")  
Survey possible

Only ground-layer  
corrected by ASM

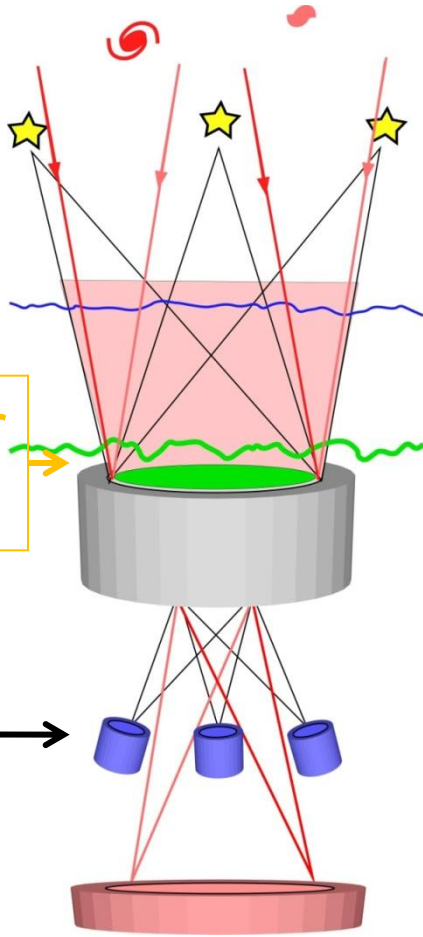

multi-WFS

Wide-field camera & spectrograph

Subaru (wider FoV than 30m)

## MOAO

FoR: 3~5 arcmin  
FoV: a few arcsec  
diffraction limited  
know target

Only the direction  
of each object

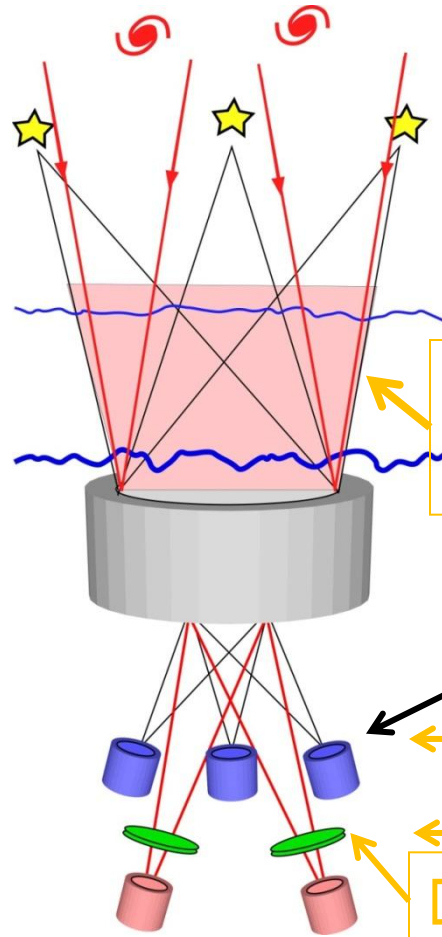

複数WFS

open-loop

DM for each object

IFU spectrograph

TMT (larger FoR than 8m)