

IR High Resolution Spectrograph for IR RV Exoplanet Search

Tomonori Usuda (Subaru Telescope)

M. Tamura, M. Hayashi, W. Aoki, H. Izumiura (Subaru/NAOJ)

B. Sato (Tokyo Institute of Technology Univ.)

T. Kurokawa (Tokyo Univ. of Agriculture and Technology)

and

Y. Ikeda (Kyoto Sangyo University)

J. Rayner (IfA, UH)

Background & Purpose

- **Habitable Earth-like exoplanets** around low-mass M stars and Brown dwarfs by a high precision (**1m/s**) near IR radial velocity (RV) spectrograph
- Comparison with other projects on 8-10m telescopes
 - IRCS-HRU: $>1.4\mu\text{m}$, $\sim 10\text{m/s}$, multi-purpose
 - VLT (CRIRES): $d\lambda \sim 0.02\mu\text{m}$, >10 times narrower
 - Gemini (PRVS), GTC (NAHUAL): Not funded

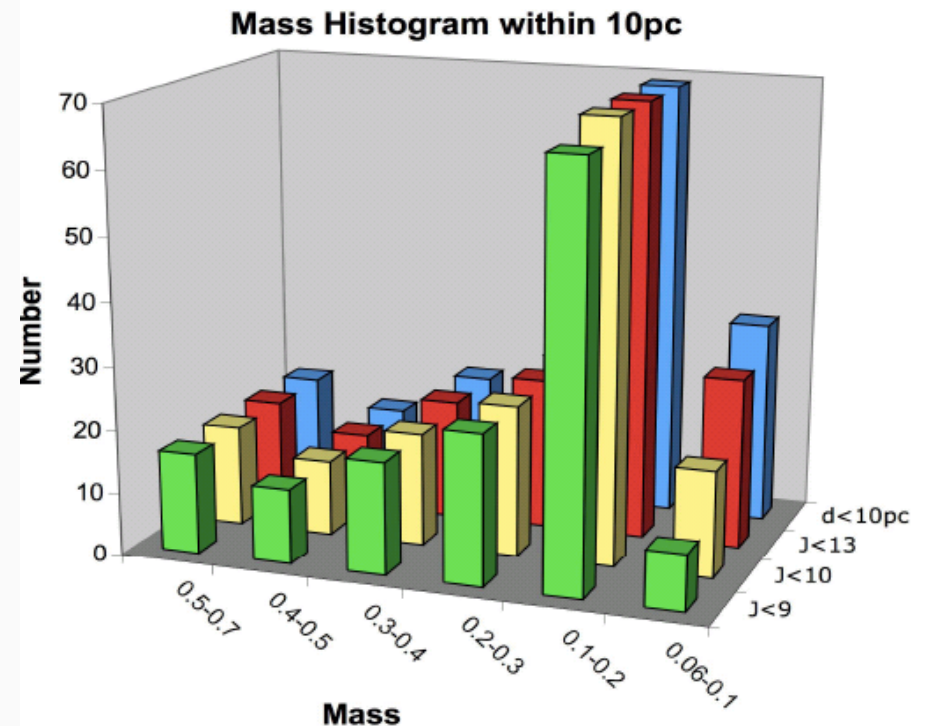
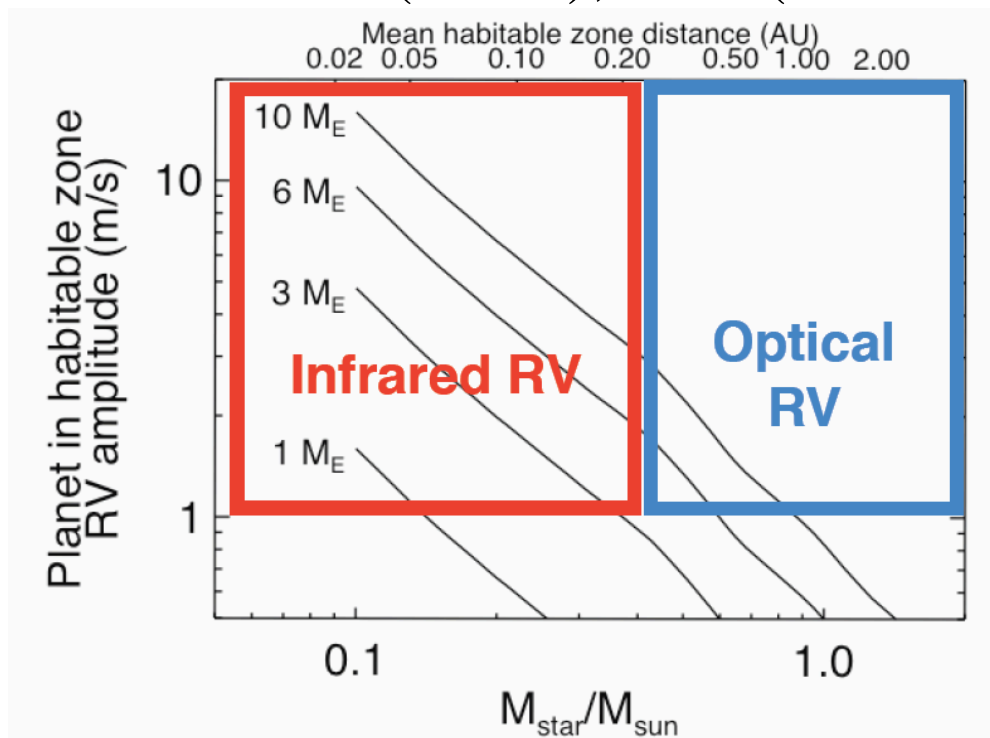

Why observe in the near-IR?

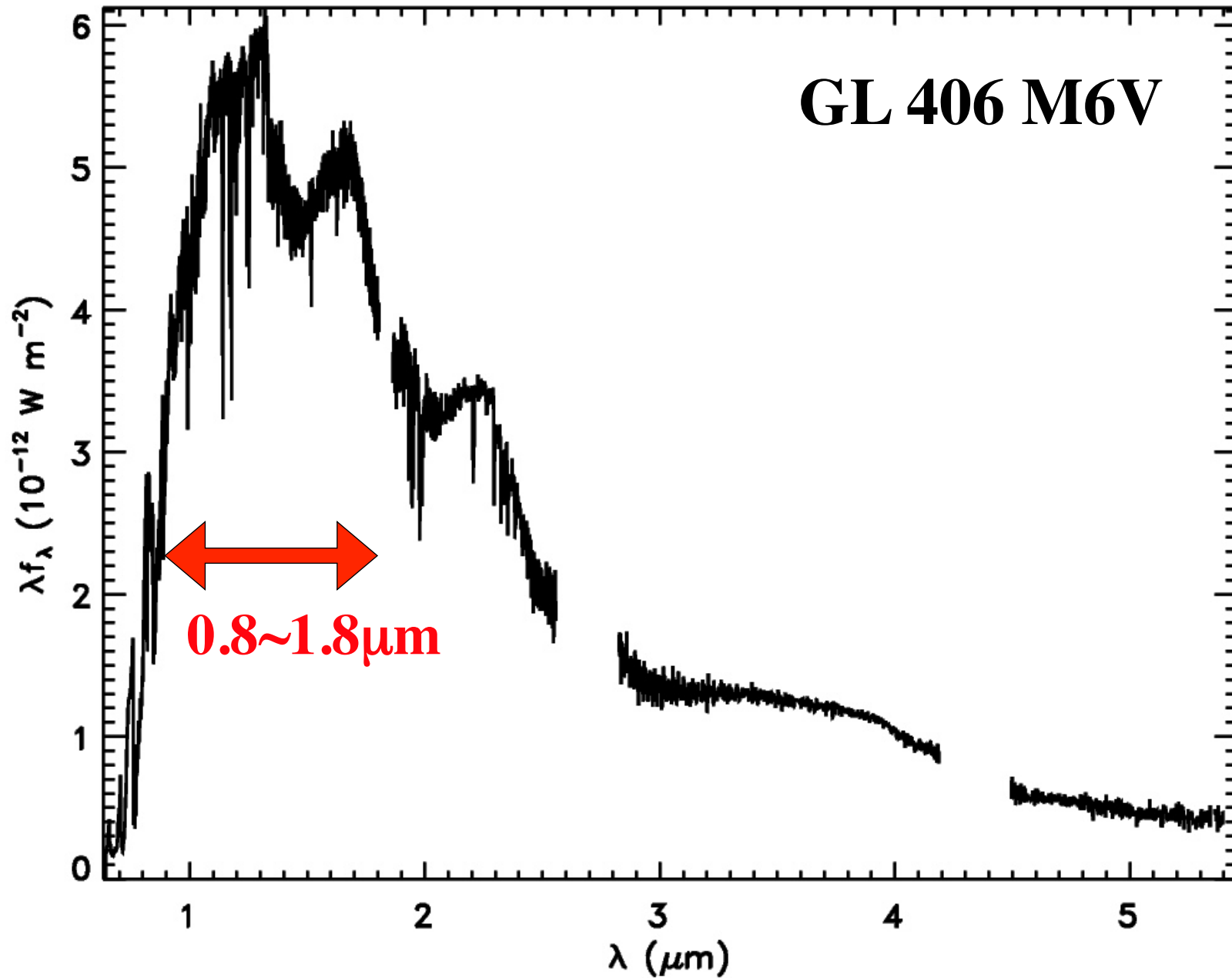

Specifications Conceptual Design

Wavelength	1.1~1.85 μm (goal: 0.8~1.85 μm)
Spectral Resolution	$\sim 70,000$ (3 pixel sampling)
Pixel scale	0.1 arcsec pixel⁻¹
Slit size	0.3 x 3.0 arcsec
Dispersion Device	ZnSe (or ZnS) Immersion Grating : Fixed / No mechanism
IR detector	HAWAII-2RG x 2
Temperature	~ 220 K (optics) & 77 K (detector & optics)
AO188 I/F	AO188 is necessary / Optical fiber feed
Spectral Calibration	Gas cell (in AO188) and AstroComb

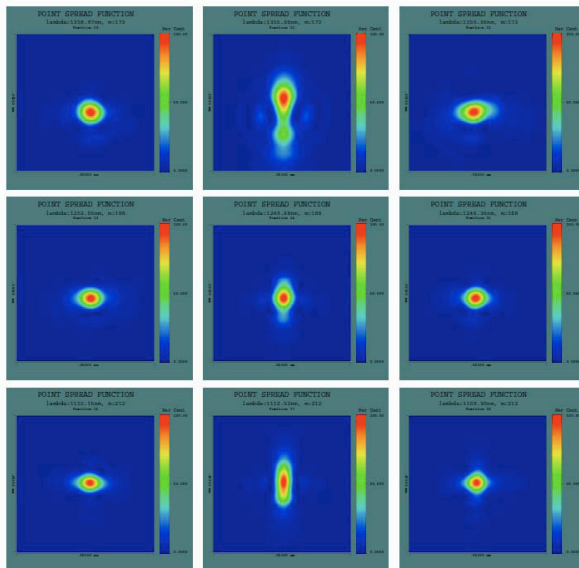

**J-band PSF
(3 pixel)**

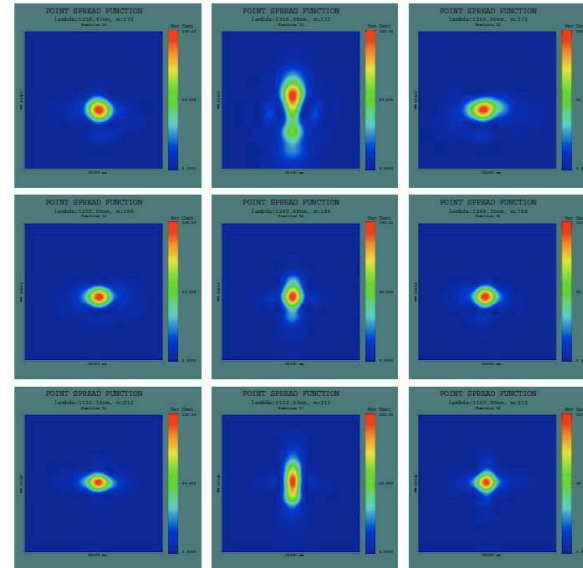

**H-band PSF
(3 pixel)**

Optics Layout

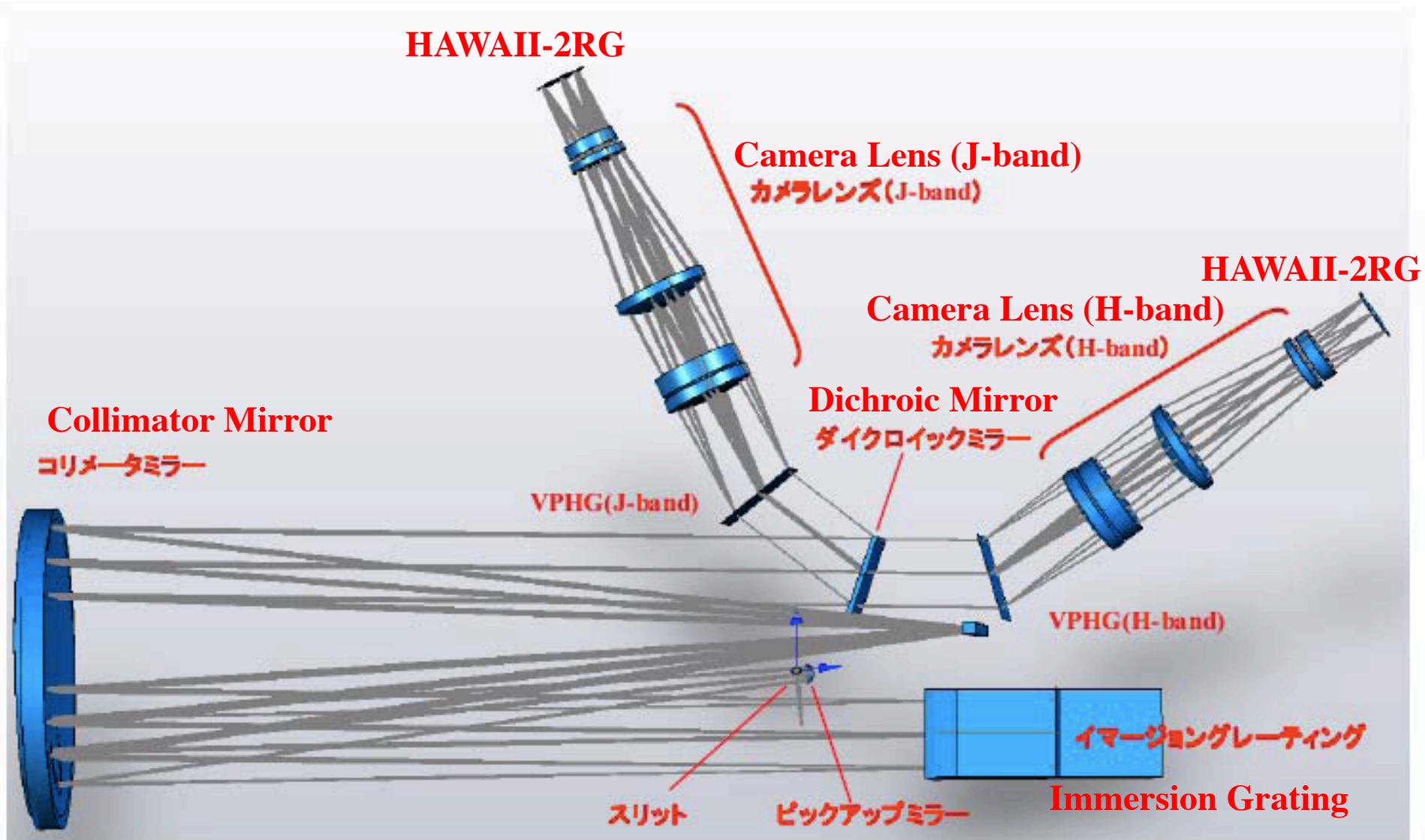

~0.9 meter



λ Calibration Lasercomb (Astrocomb)

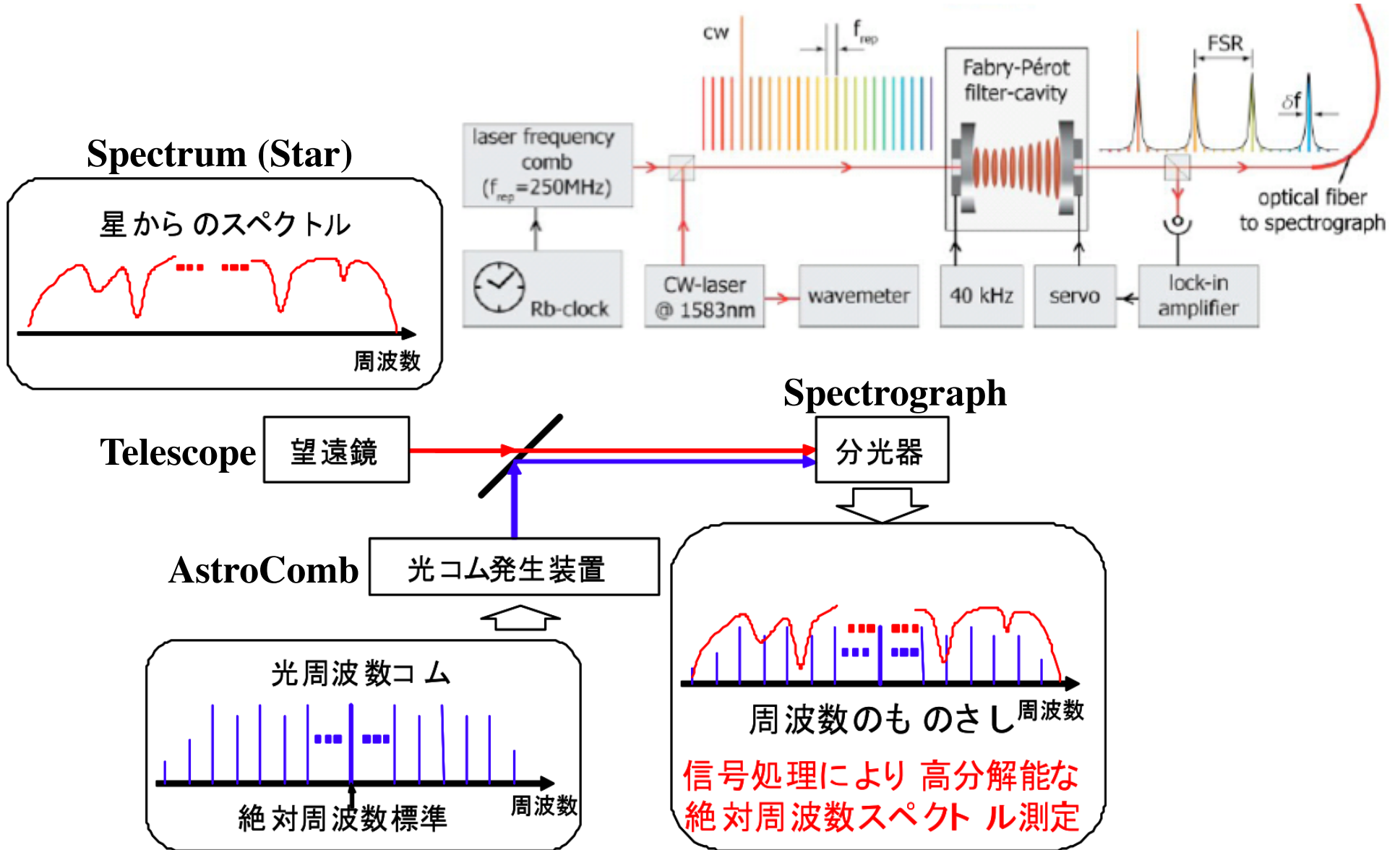

Opto-Mechanical Concept

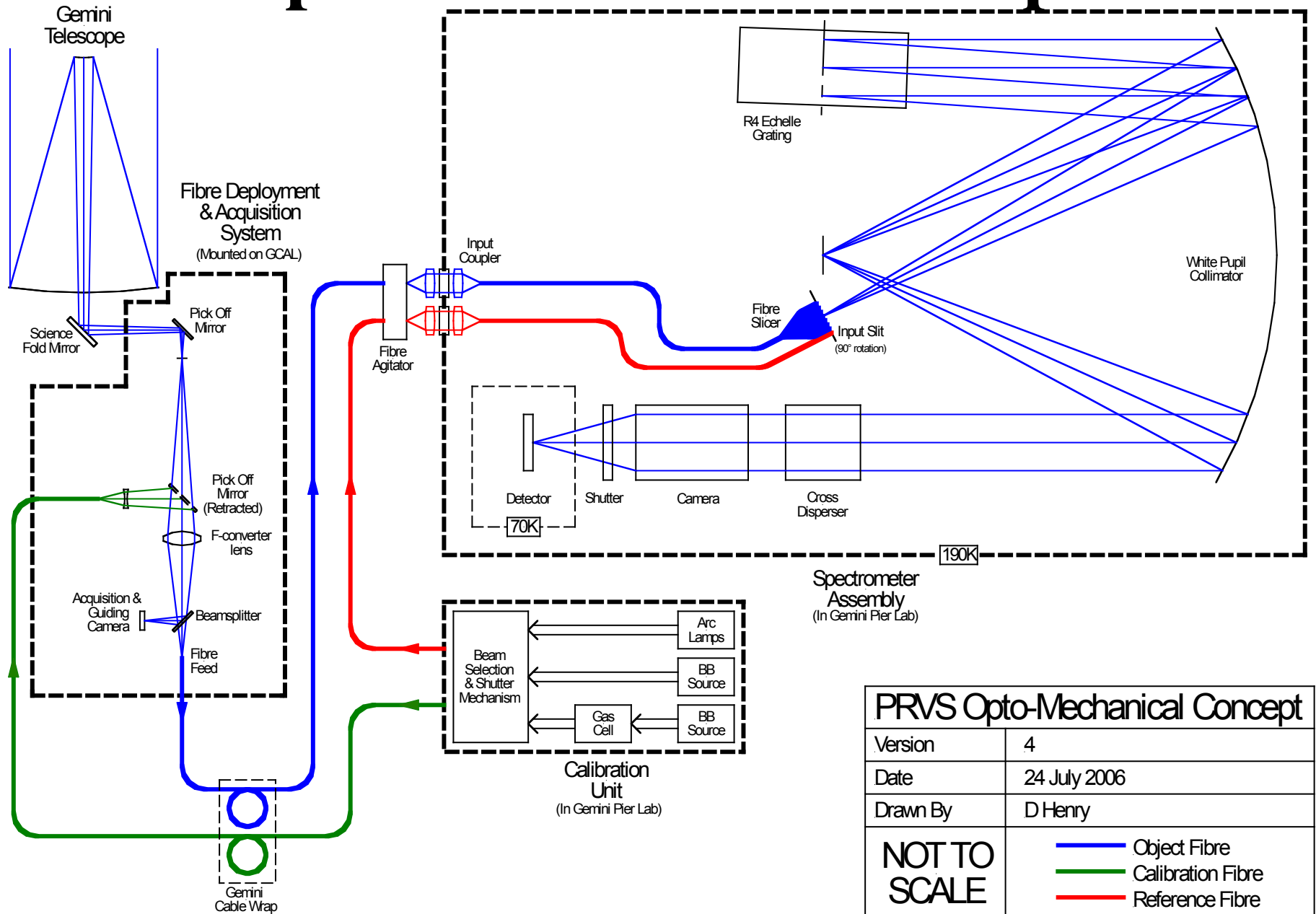

PRVS Opto-Mechanical Concept

Version	4
Date	24 July 2006
Drawn By	D Henry
NOT TO SCALE	<ul style="list-style-type: none"> — Object Fibre — Calibration Fibre — Reference Fibre

Locations and Schedule

- Location
 - Spectrograph's design is simple and compact
 - Fiber feed -> Any places
- Schedule
 - Grant-in-Aid Fund: 2010~2014
 - Preliminary Design Phase: 2010~2011
 - Final Design Phase: 2011~2012
 - AIV: 2012~2013
 - Commissioning: 2013
 - Survey starts from 2013/2014